



Pre-feasibility Study Concerning the Replacement of the Existing Champlain Bridge



Summary Report

JCCBI Contract No 61100

Revision 01 | March 2011



Les Ponts Jacques Cartier et Champlain Incorporée
The Jacques Cartier and Champlain Bridges Incorporated

Canada





Les Ponts Jacques Cartier et Champlain Incorporée
The Jacques Cartier and Champlain Bridges Incorporated
Canada



Pre-feasibility Study Concerning the Replacement of the Existing Champlain Bridge

Summary Report

Date: 2011-03-31

CONSORTIUM BCDE



DESSAU





The Jacques Cartier and Champlain Bridges Incorporated
Ministère des Transports du Québec

Pre-feasibility Study Concerning the Replacement of the Existing Champlain Bridge

Summary Report

March 31, 2011

Prepared by:



Jean-Claude Therrien, Eng., M.S.E., OIQ 016880

Project Manager

Consortium BCDE

1060, University St, Suite 600
Montréal (Québec) Canada H3B 4V3
Phone : 514.281.1010
Fax : 514.281.1060

TABLE OF CONTENTS

INTRODUCTION	6
1 URBAN INTEGRATION.....	7
1.1 Objectives	7
1.2 Review of regional planning documents	7
1.3 Increased traffic capacity of the new replacement structure	7
1.4 Creation of a corridor dedicated to public transport.....	8
1.5 Meeting with regional planners	8
1.6 Results of the documentary analysis and meetings	9
1.7 Consultation	10
2 TRANSPORTATION AND TRAFFIC NEEDS	11
2.1 Existing traffic characteristics.....	11
2.2 Evaluation of travel demand	12
2.2.1 Existing demand.....	12
2.2.2 Future demand.....	13
2.3 Simulated scenarios in the 2026 horizon and number of lanes required.....	14
2.4 Recommendations	16
3 GEOMETRY AND ROADWAY WORKS	18
3.1 Objectives	18
3.2 Design parameters.....	18
3.2.1 Design speed	18
3.2.2 Cross section	19
3.3 Proposed layout	21
3.3.1 Horizontal alignment	21
3.3.2 Vertical alignment.....	21
3.4 Exclusive lane for public transit.....	22
3.5 Assessment of impacts	24
3.5.1 On existing infrastructure.....	24
3.5.2 On land acquisitions.....	25
3.5.3 On public services and utilities.....	25
3.5.4 On environment.....	25
3.5.5 Traffic management during construction	26
4 BRIDGE SOLUTIONS.....	27
4.1 Comparative analysis.....	27
5 “TUNNEL” SOLUTIONS	31
5.1 Enumeration of possible alternatives.....	31
5.1.1 Bored tunnel solutions	31
5.1.2 Under-river tunnel solutions	33
5.1.2.1 Construction using immersed caissons.....	35

5.1.2.2	“Dry bed” construction behind cofferdams	35
5.1.2.3	Environmental Impact	35
5.1.3	<i>Construction costs and periods</i>	36
5.1.4	<i>Comparative table of tunnel solutions</i>	36
5.1.5	<i>Retained solution</i>	37
5.2	Development of the retained solution	39
5.2.1	<i>Main elements</i>	39
5.2.1.1	Horizontal alignment and longitudinal section.....	39
5.2.1.2	Connections and Interchanges	39
5.2.1.3	Functional section.....	40
5.2.1.4	Civil engineering structures.....	40
5.2.1.5	Ventilation installations	40
5.2.1.6	Operating and safety installations.....	41
5.2.1.7	Preliminary approach to safety and THG features	41
5.2.1.8	Construction methods.....	42
5.2.1.9	Provisional work plan.....	43
5.2.1.10	Construction and operating costs	43
5.2.2	<i>Options</i>	43
5.3	Recommendations	44
6	THE FUTURE OF THE EXISTING STRUCTURES.....	45
6.1	The ice structure	45
6.2	The existing Champlain Bridge.....	45
6.2.1	<i>Maintenance</i>	45
6.2.2	<i>Seismic resistance</i>	45
6.2.3	<i>Demolition</i>	46
7	ENVIRONMENTAL ASPECTS.....	47
7.1	Process and methodology	47
7.2	Main human and natural constraints of the site	47
7.3	Anticipated impacts of the bridge options	48
7.4	Anticipated impacts of the tunnel options	48
7.5	Anticipated impacts of the demolition options.....	51
7.6	Legal, regulatory and administrative requirements.....	52
8	CAPITAL AND OPERATING COSTS	53
9	FINANCIAL CONSIDERATIONS AND METHODS OF DELIVERY	56
9.1	Use of the bridge for the passage of public utilities	56
9.2	Project delivery methods.....	56
9.3	Project schedules according to delivery methods.....	59
9.4	Cash flow analysis	61
9.4.1	<i>Cash flows according to delivery methods</i>	61
9.4.2	<i>Sensitivity analysis</i>	63



9.4.2.1	Construction Costs	63
9.4.2.2	Short Term Interest Rates.....	64
9.4.2.3	Conclusion	64
9.5	Economic impacts of the project	64

Tables

Table 2-1: Definition of Levels of Service (LOS)	12
Table 2-2: Number of users in the reserved lane of the Champlain Bridge and on the Métro yellow line	13
Table 2-3: Results of Simulations With 2026 Demand – AM Peak Period	15
Table 2-4: Results of Simulations With 2026 Demand – PM Peak Period	15
Table 4-1 – Comparative analysis of the “bridge” solutions	29
Table 5-1: Comparative multicriteria analysis of “tunnel” solutions	38
Table 7-1: Comparative environmental multicriteria table for various bridge solutions.....	48
Table 7-2: Comparative multicriteria environmental table between various tunnel solutions	49
Table 7-3: Comparative environmental multicriteria table of the various demolition options	51
Table 8-1: Capital cost of bridge and tunnel solutions.....	53
Table 8-2: Representative Annual Operating and Maintenance Costs of a Bridge Solution	54
Table 8-3: Representative Annual Operating and Maintenance Costs of a Tunnel Solution.....	55

Figures

Figure 2-1: Distribution of Hourly Volumes for an Average Working Day (June 2004).....	11
Figure 3-1: Typical Cross Sections for 3 or 4 lanes + ELPT per direction	20
Figure 3-2: Location of the New Champlain Bridge.....	21
Figure 3-3: Route of the LRT option.....	23
Figure 3-4: Route of the BRT option	24
Figure 5-1: Typical Cross Section, Alternative A.....	32
Figure 5-2: Typical Cross Section, Alternative B.....	32
Figure 5-3: Typical cross section of under-river solutions	34
Figure 5-4: Comparison of construction costs	36
Figure 9-1: Summary Project Schedule by Delivery Method	60

Copyright and confidentiality

"This engineering document is the work of the BCDE Consortium and is protected by law. This report is intended exclusively for the purposes mentioned in it. Any reproduction or adaptation, partial or complete, is strictly prohibited without the prior written authorization of The Jacques Cartier and Champlain Bridges Incorporated and the Ministère des Transports du Québec."

REVISION AND ISSUE LOG		
Revision No.	Date	Description of the change and/or issue
00	2011-02-24	Final Report
01	2011-03-31	Revised Final Report

INTRODUCTION

In May 2009, Jacques Cartier and Champlain Bridges Incorporated (JCCBI) issued a Canada-wide request for proposals for the execution of Project No. 61100, a pre-feasibility study concerning the replacement of the existing Champlain Bridge.

In October of that same year, Consortium BCDE, comprised of the consulting firms BPR, CIMA+, DESSAU and EGIS, was commissioned to conduct the study.

Given the functional obsolescence and current condition of the existing Champlain Bridge, JCCBI, in association with the Ministère des Transports du Québec, and with the authorization of the Federal Government, decided to study the pertinence and necessity of replacing the existing bridge with a modern structure adapted to current and future needs of the many categories of users; composed principally of personal, commercial and public transportation vehicles within the greater Montreal region.

The main goal of the pre-feasibility study was to validate the advisability of constructing a new replacement structure and by doing so, provide decision-makers with pertinent information necessary to determine whether or not to pursue the project beyond the preliminary stage.

The Consortium was initially required to develop and analyze various replacement solutions, including alternative options for either a bridge or a tunnel. It was then asked to reach a conclusion about the future of the existing bridge and the adjacent ice control structure. The conclusions of these studies were supported by a detailed evaluation of the transportation needs (all modes combined) and traffic demands.

In the following pages, this summary report details the overall results of the study process:

- ▶ The necessary urban integration of the project;
- ▶ Current and foreseeable transportation and traffic needs;
- ▶ The geometric layout and on-land road system;
- ▶ Bridge solutions;
- ▶ Tunnel solutions;
- ▶ Future of the existing bridge and the ice control structure;
- ▶ Environmental aspects;
- ▶ Capital and operating costs;
- ▶ Socio-economic and financial considerations and implementation modes.

1 URBAN INTEGRATION

1.1 OBJECTIVES

The *Urban Integration* segment of the pre-feasibility study concerning the replacement of the existing Champlain Bridge had the following main objectives:

- ▶ Identify the principal orientations adopted by regional bodies that could have an influence on the replacement of the Champlain Bridge by a new structure (bridge or tunnel);
- ▶ Based on these orientations, identify the positive components and the potentially controversial elements of the project;
- ▶ Propose an approach that would minimize the opposition to such a project, maximize the impact of its supporters and obtain the support of the greatest possible number of stakeholders for a common goal.

1.2 REVIEW OF REGIONAL PLANNING DOCUMENTS

BCDE began by reviewing a large number of planning documents prepared in recent years and dealing in some way with the Champlain Bridge and the Île des Sœurs Bridge.

Out of the many studies consulted, some twenty were selected and used in preparing a summary of regional planning and associated risks and opportunities as a function of their relevance to the Champlain Bridge replacement project.

Two major themes were revealed by the analysis of these documents with respect to the Champlain Bridge replacement project: the first one refers to a potential increase of traffic capacity of the new structure and the second to the creation of a corridor dedicated to public transport.

1.3 INCREASED TRAFFIC CAPACITY OF THE NEW REPLACEMENT STRUCTURE

The great majority of studies consulted tend to demonstrate that any increase in the capacity of the link between the two shores would run counter to the policies that the various levels of government wish to establish in the next few years. Here are some examples:

- ▶ The Québec government has adopted the objective of reducing greenhouse gases (GHG) by 6% below their level of 1990 in the 2012 horizon and 20% in the 2020 horizon. The road transport sector accounted for 33% of Québec GHG emissions in 2006¹. Efforts to reduce the use of

¹ Québec Inventory Of The GHGs Emissions In 2006 And Their Growth Since 1990, MDDEP, 2008

automobiles will be very important in the next few years in reaching this object, especially in the greater Montreal metropolitan region.

- ▶ The transportation plan of the City of Montréal has adopted the objective of a 15% reduction in car trips to Montréal during the peak traffic period with respect to trips projected in 2021.
- ▶ The Société du Havre de Montréal project of reconfiguring the Bonaventure Expressway as an urban boulevard cannot be executed in its current form if the configuration of the future structure encourages an increase in automobile use in this corridor. In fact, the projected reconstruction of the Bonaventure axis will reduce its capacity, thus generate long traffic queues.

1.4 CREATION OF A CORRIDOR DEDICATED TO PUBLIC TRANSPORT

Such a corridor in the Champlain Bridge alignment has been unanimously accepted with only one exception², whether with a guided mode such as a light rail transit system (LRT) type or with separate lanes exclusively reserved for buses.

The Réseau de transport de Longueuil (RTL) is very favourable to the immediate implementation of an LRT system in the A-10/Champlain Bridge alignment, linking the nearer west South Shore to downtown Montréal, because this is the only way to resolve the problems of reliability and safety of the present reserved lane on the bridge, of traffic congestion on the approaches to the downtown terminal and of congestion at the bus terminal station during the evening rush hour.

The Ville de Montréal transport plan favours the increase of public bus transport in the Bonaventure corridor in the short term, without compromising the implementation of an LRT system in the future.

Expansion of public transport in the Champlain Bridge axis is a priority for the Société du Havre de Montréal and the Communauté métropolitaine de Montréal (CMM).

While an LRT system is recommended for the Champlain Bridge axis in most of the other studies consulted, they do not generally take a position on when it should be implemented. Many bodies are waiting for the result of the JCCBI study to adopt a position on the future of an LRT.

1.5 MEETING WITH REGIONAL PLANNERS

BCDE representatives met with a dozen bodies in the Montreal region identified as potentially having an influence on the Champlain Bridge replacement project. These meetings, which were

² The Nicolet Commission (2003) did not recommend an LRT, based on its slight appeal to new users and very low impact on solving traffic congestion problems in this axis.

informal in nature, were designed to first present the basic Champlain Bridge replacement scenario under study and then hear their concerns about this project and obtain some understanding of their long-term vision.

Meetings took place with the following organizations:

- ▶ Borough of Verdun
- ▶ Port of Montréal
- ▶ Sud-Ouest Borough
- ▶ Ville de Brossard
- ▶ Communauté métropolitaine de Montréal (CMM)
- ▶ Association des CIT (Conseils intermunicipaux de transport)
- ▶ Ville de Longueuil and the Réseau de transport de Longueuil (RTL)
- ▶ Société du Havre de Montréal
- ▶ Comité interrégional pour le transport des marchandises (CITM)
- ▶ Agence métropolitaine de transport (AMT)
- ▶ Ville de Montréal
- ▶ The Jacques Cartier and Champlain Bridges Incorporated (JCCBI)

1.6 RESULTS OF THE DOCUMENTARY ANALYSIS AND MEETINGS

Analysis of the various planning documents, completed by meetings with the main organizations concerned, resulted in the following list of findings and expectations:

- ▶ The Champlain Bridge is a major link in the major highway network of the metropolitan region, both for commuters and through traffic. It plays a very important role in trucking and especially in the transportation of dangerous goods;
- ▶ During peak periods, the reserved lane on the Champlain Bridge carries as many people by public transport as the other lanes do by private cars, and more people than on the Métro yellow line (Longueuil). It therefore plays a major role for both these modes;
- ▶ The reliability and permanence of the reserved lane is a very great concern for a number of stakeholders;
- ▶ In this respect, inclusion of a high capacity public transport mode (of the LRT type) on the new structure is supported by virtually everyone;
- ▶ Additional capacity on the new structure is a source of concern for many people with respect to achieving the goals of reducing greenhouse gases and modal shift to public transport;

- ▶ If the new structure is a bridge, its architectural aspect will be important because the Champlain Bridge (or its replacement) is perceived as a major gateway to the city;
- ▶ The "early consultation" process conducted by BCDE was very much appreciated by the stakeholders, who all hoped it would continue throughout the project.

1.7 CONSULTATION

Replacement of the Champlain Bridge will not be accepted by the public if it takes place in isolation. It should be considered within the framework of the redesign of the Turcot Interchange, the reconstruction of the Bonaventure Expressway and the Griffintown development, and be the object of a formal consultation by regional and local authorities; it must also take the major governmental orientations into consideration.

All the organizations consulted greatly appreciated that the consultative approach of JCCBI and the MTQ was applied to them very early on, in order to learn their concerns with respect to a project of such major importance as replacement of the Champlain Bridge. They were convinced that their involvement so early in the process of developing a project on this scale promises success as long as it continues throughout the project development process. They are all, in their own way, participating in planning transport in the greater Montréal region and will all be affected in some way by replacement of the Champlain Bridge.

2 TRANSPORTATION AND TRAFFIC NEEDS

2.1 EXISTING TRAFFIC CHARACTERISTICS

With some 57 million crossings per year, the Champlain Bridge is one of the busiest bridges in Canada.

In 2009, the average daily traffic on this bridge was 156,000 vehicles; among them, some 12,000 trucks and 1,900 buses, of which 900 travel on the reserved lane during the morning and evening rush hours. The largest volumes are observed during summer, while in winter, there is a substantial reduction. On a weekly basis, Fridays have the largest volumes, while Saturday and Sunday volumes are the lowest.

On a daily basis, the average hourly volumes in each direction are summarized in Figure 2-1. It should be noted that during the morning peak period (PPAM), the flows reach or exceed, for more than two hours, the bridge's theoretical capacity of 2,000 vehicles/lane. It should also be noted that the presence of the reserved lane during peak periods in the minor direction imposes a serious restriction on automobile traffic, which behaves at or near capacity on the two remaining lanes during the most part of those two periods. It can thus be assumed that, during more than 6 hours, an important number of vehicles are diverted to other bridges because of the presence of the reserved lane.

Figure 2-1: Distribution of Hourly Volumes for an Average Working Day (June 2004)

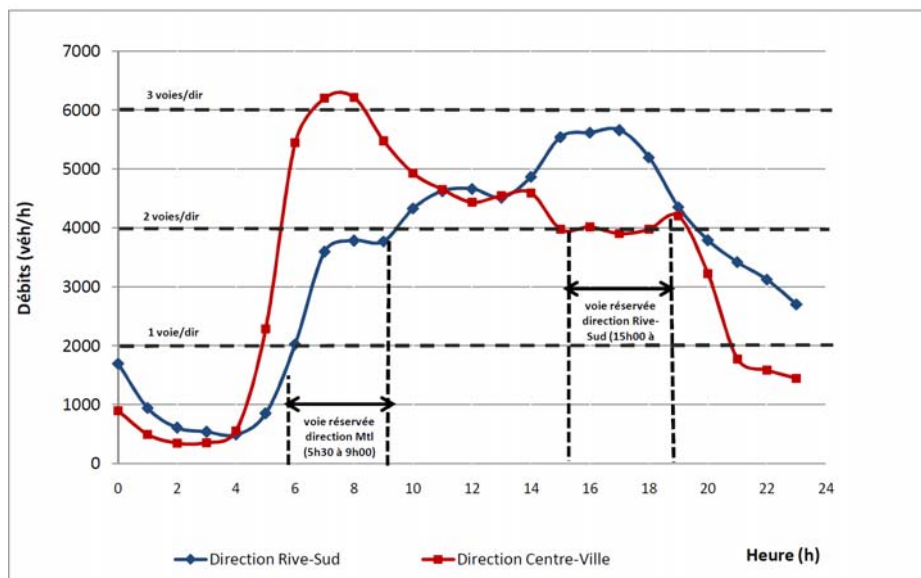

With an hourly volume of 6,200 vehicles toward Montréal during the AM peak, the Levels of Service (LOS) is “E” as defined in Table 2-1, with a density estimated at 24.7 veh/km/lane. The theoretical limit between the “E” and “F” LOS is a density of 28. However, one can assume that the actual density on the bridge is higher than the calculated density: in fact, given the recurrent congestion on the bridge approaches during peak hours, it can be estimated that they operate at LOS “F”. In the opposite direction during the PM peak, it can also be noted that the LOS is at the limit of “F” with 4,000 veh/h on the two travelled lanes.

Table 2-1: Definition of Levels of Service (LOS)

LEVEL OF SERVICE	TRAFFIC DENSITY veh/ km/ lane	DESCRIPTION
A	< 7	Free flow. Excellent level of comfort and maneuverability.
B	7 to 11	Stable flow. Very good level of comfort and maneuverability.
C	11 to 16	End of low density stable flow. Acceptable level of comfort and maneuverability.
D	16 to 22	High density stable flow. Serious speed restrictions. Poor level of comfort and maneuverability.
E	22 to 28	Unstable flow. Capacity of the road component reached. Low and uniform speed. Zero comfort level and maneuverability.
F	> 28	Forced flow or congestion.

Sources: MTQ and Transportation Research Board, National Research Council, USA

2.2 EVALUATION OF TRAVEL DEMAND

2.2.1 Existing demand

During the morning peak period (PPAM)³, downtown Montréal and its immediate periphery is the most important destination of passenger vehicles travelling on the bridge (32.6%). Longueuil and Brossard account for nearly 50% of the origins of the car trips; including St-Jean-sur-Richelieu and Carignan-Chambly, nearly 69% of trip origins are accounted for.

During the afternoon peak period (PPPM), users going to Montréal are 55% from Longueuil and Brossard, and 23% from outside the greater Montréal region, while users leaving Montreal are nearly 50% heading for Longueuil and Brossard but only 10% outside the region.

³ Source: MTQ, 2006 simulations based on 2003 origin-destination survey

Person trips by public transport (PT) are at least as numerous as those made by car. The reserved lane, operating in the contraflow direction from 5:30 to 9:30 am and 3:00 to 7:30 pm, supports significant traffic in terms of buses and users. As shown by Table 2-2, during the morning peak, more users use the Champlain Bridge reserved bus lane than the yellow line of the Métro. In 2010, during the morning peak period, nearly 20,000 users used the reserved bus lane on the Champlain Bridge. This represents growth of 16% over the last five years. New Québec government assistance programs strongly encouraged the public transport organizing authorities (AOT) to increase their service offerings, which then attracted a new clientele. Future growth will come in large part from maintaining and improving these programs.

Table 2-2: Number of users in the reserved lane of the Champlain Bridge and on the Métro yellow line

TRANSPORT MODE	MORNING PEAK	24 HOURS
Métro yellow line	16,000	54,000
Champlain Bridge reserved lane	20,000	50,000

Sources: RTL and AMT

2.2.2 Future demand

In 2026⁴, with the current bridge configuration, the following changes in travel habits on the Champlain Bridge are projected:

- ▶ Increase of 4% for the 24-hour period
- ▶ Increase of 16% in PPAM and 9% in PPPM in the minor direction
- ▶ Increase of 9 to 11% between the two peak periods
- ▶ No sensitive change in PPAM and PPPM in the major direction

At this stage, it is difficult to estimate how demand will grow after 2026. Implementation of a public transport system on exclusive lanes like a LRT could substantially influence future travel demand on the Champlain Bridge axis, as well as modal choices⁵.

⁴ Source : MTQ, Simulations MOTREM03, 2026

⁵ The 2004 AMT study projected an increase of 30% in the number of public transit passengers with the commissioning of a LRT in 2016

2.3 SIMULATED SCENARIOS IN THE 2026 HORIZON AND NUMBER OF LANES REQUIRED

The following lane configuration scenarios for the A-15/Champlain Bridge/A-10 axis were used in simulations in the 2026 horizon:

- ▶ 0: Current configuration: 3 lanes/major dir.⁶ and 2 lanes/minor dir. on the bridge, 2 lanes/dir. on A-15);
- ▶ A: 3 lanes/direction on the bridge, 2 lanes/direction on A-15;
- ▶ B: 3 lanes/direction on the bridge, 3 lanes/direction on A-15;
- ▶ C: 4 lanes/direction on the bridge, 2 lanes/direction on A-15;
- ▶ D: 4 lanes/direction on the bridge, 3 lanes/direction on A-15.

Tables 2-3 and 2-4 illustrate, for each of the scenarios and for the AM and PM peak periods respectively, the flows anticipated per direction in 2026 on the bridge and on A-15 between Île des Soeurs and the Atwater interchange, a section that currently has only 2 lanes per direction, unlike the rest of this highway.

In **Scenario A**, when three lanes per direction are provided on the bridge (i.e. elimination of the reserved lane) and the A-15 continues with only two lanes, demand in the direction opposite the peak increases substantially on the bridge (1,900 vehicles during PPAM and 3,100 vehicles during PPPM) and, to a lesser extent, on the A-15 (1,000 vehicles during PPAM and 400 vehicles during PPPM). These results suggest a need for additional lanes in the direction opposite the peak, especially on the bridge.

In **Scenario B**, with the A-15 and the Champlain Bridge having three lanes per direction, a nearly uniform increase is observed on all sections (2,100 to 3,600 vehicles), except on the bridge in the peak direction, where the increase is relatively small (600 vehicles), because the configuration does not change.

Adding a 4th lane on the Champlain Bridge while maintaining the configuration of the A-15 at two lanes (**Scenario C**) results in a relatively large increase in flow on the bridge during the morning peak period (2,800 vehicles toward Montréal and 2,300 toward the South Shore South Shore) and an even larger increase during the afternoon peak (4,700 vehicles toward Montréal and 3,700

⁶ Major direction = toward Montréal at AM peak, toward the South Shore at PM peak

vehicles toward the South Shore). On the A-15, the increase is much smaller (400 to 1,200 vehicles), given that the capacity remains unchanged.

By adding a 4th lane on the Champlain Bridge and a 3rd on the A-15 (**Scenario D**), the increases in traffic compared to scenario 0 (current) are very large, from 2,300 to 3,700 veh/h in the morning and 4,000 to 5,300 veh/h in the afternoon, on both the A-15 and the bridge.

Table 2-3: Results of Simulations With 2026 Demand – AM Peak Period

DESCRIPTION OF THE SCENARIO	FLOW on BRIDGE (PPAM – ALL VEHICLES)				FLOW on A-15 (PPAM – ALL VEHICLES)			
	TO MONTRÉAL		TO SOUTH SHORE		NORTHWARD		SOUTHWARD	
	Veh/h	Incr.	Veh/h	Incr.	Veh/h	Incr.	Veh/h	Incr.
0: Current geometry	17,400	(base)	9,000	(base)	12,400	(base)	9,100	(base)
A: 3L bridge - 2L A-15	17,600	+ 200	10,900	+ 1,900	12,400	0	10,100	+ 1,000
B: 3L bridge - 3L A-15	18,000	+ 600	11,200	+ 2,200	15,300	+ 2,900	11,200	+ 2,100
C: 4L bridge - 2L A-15	20,200	+ 2,800	11,300	+ 2,300	12,800	+ 400	10,300	+ 1,200
D: 4L bridge – 3L A-15	20,600	+ 3,200	11,800	+ 2,800	16,100	+ 3,700	11,400	+ 2,300

Table 2-4: Results of Simulations With 2026 Demand – PM Peak Period

DESCRIPTION OF SCENARIO	FLOW on BRIDGE (PPPM – ALL VEHICLES)				FLOW on A-15 (PPPM – ALL VEHICLES)			
	TO MONTRÉAL		TO SOUTH SHORE		TO MONTRÉAL		TO SOUTH SHORE	
	Veh/h	Incr.	Veh/h	Incr.	Veh/h	Incr.	Veh/h	Incr.
0: current geometry	11,900	(base)	19,800	(base)	10,900	(base)	12,200	(base)
A: 3L bridge - 2L A-15	15,000	+ 3,100	19,900	+ 100	11,300	+ 400	12,200	0
B: 3L bridge - 3L A-15	15,400	+ 3,500	20,400	+ 600	14,300	+ 3,400	15,800	+ 3,600
C: 4L bridge - 2L A-15	16,600	+ 4,700	23,500	+ 3,700	11,500	+ 600	12,700	+ 500
D: 4L bridge – 3L A-15	17,200	+ 5,300	23,800	+ 4,000	14,300	+ 4,000	16,800	+ 4,600

Analysis of the levels of service (LOS) of the various scenarios shows that adding a **4th lane on the bridge** (Scenarios C and D) would offer little benefit in terms of levels of service on the Champlain – A-15 axis, because during the PPPM and particularly at the peak hour, the LOS remains at “F” on the bridge and drops from “E” to “F” on the A-15 in the south direction. Despite the lower LOS, it should be noted that these scenarios provide a substantial increase in capacity in the Champlain Bridge axis. This increase in capacity from a 4th lane on the Champlain Bridge has significant effects on the other river crossings, i.e. the Honoré-Mercier, Victoria and Jacques-Cartier bridges, the Louis-H.-La Fontaine bridge-tunnel and the future Autoroute 30 bridge. In fact,

preliminary simulations made by the MTQ suggest there would be relatively large reductions in the volume of traffic on these bridges. If at first glance this seems to be an advantage for the other river crossings, it is important to remember that these simulations are preliminary and do not take into account the effects of congestion and queues that the new traffic inflows on the Champlain Bridge could cause on the A-15, A-10, Highway 132 or the Bonaventure Expressway (or Boulevard?).

2.4 RECOMMENDATIONS

Analysis of the simulation results demonstrates that Scenario C, consisting of a configuration in which the Champlain Bridge has four lanes in each direction and the A-15 has two lanes in each direction, should not be retained. If the bridge were to include 4 lanes per direction, it would be essential for the A-15 to be widened to three lanes in each direction.

The addition of a fourth lane in each direction on the Champlain Bridge would obviously allow it to carry a larger flow. However, according to the demand simulated for the 2026 PPPM, this fourth lane would not result in an improvement in traffic conditions on this main artery: in fact, whether the bridge has three or four lanes, the level of service would remain at “F” and at the same time cause significant transfers of traffic from other bridges to the Champlain Bridge. A detailed analysis of these transfers is beyond the scope of this study and so, their impacts – positive or negative – were not evaluated.

It is difficult to assess the merits of a fourth lane on the Champlain Bridge because the levels of service were analyzed essentially for the bridge corridor only. To properly and fully assess the four lane scenario would require a more extensive analysis of just the Champlain Bridge corridor while quantifying and evaluating the impacts on the other river crossings.

Additional carriageway widths on the future replacement structure should be reserved either for public transport or for emergency stop, or both. In fact, the recurrence of incidents on the Champlain Bridge and the Bonaventure Expressway (on average 6 a day), combined with bridge maintenance activities, means that the impact of these incidents on bridge capacity must be minimized.

Eventhough a reflection was made with regards to the inclusion of reserved lanes for car poolers and/or trucks, the scope of the present study did not allow BCDE to make a final recommendation on this issue. As a matter of fact, benefits from such lanes for trucks or for car poolers generally appear when those are available on relatively long distances and between major highway nodes (interchanges), and when they lead their users to precise and important destinations; the present study, limited to the bridge itself and its immediate approaches, could not properly address such an analysis covering the whole metropolitan area. Furthermore, would it be logic, on a strategic and economic basis, to implement at great cost a reserved lane for car pooling directly adjacent to a very efficient and highly expensive ELPT roadway? As for trucks, BCDE believes that the solution

rests first in the elimination of the present recurrent congestion and on the steady flow of traffic on the bridge, those two objectives being most probably reached by eliminating the present reserved lane in opposite direction and by implementing emergency stop lanes on the bridge, and by adding of a third lane in each direction along A-15 between Île des Soeurs and the Atwater interchange, thus proving a 3-lane continuity in both directions along this freeway over its entire length on the Montréal Island. This lane addition will however become an absolute necessity with the announced downgrading of a major portion of the Bonaventure Expressway to a boulevard.

3 GEOMETRY AND ROADWAY WORKS

3.1 OBJECTIVES

The *Geometry and Roadway Works* segment is intended to define the geometric characteristics, the roadway elements and the costs of the preferred solution(s) for replacing the existing Champlain Bridge, for both the bridge (or tunnel) and its approaches, and to identify their impacts on their setting.

In the process of developing solutions, the geometric design parameters to be used must first be defined; for this purpose, various considerations were taken into account:

- ▶ For bridge solutions, a clearance template for the St. Lawrence Seaway with a width of 117.5 m and a vertical clearance of 35.5 m plus 2 m for bridge maintenance and inspection needs;
- ▶ An exclusive lane for public transport in both directions (bus or LRT);
- ▶ The impact of the vertical alignment on the travel speed of heavy vehicles;
- ▶ Optimum and safe traffic conditions;
- ▶ The impact of the proposed roadways on the surroundings (land acquisition, visual appearance, noise);
- ▶ The impact on the environment (archaeological site, spawning grounds);
- ▶ The integration of existing and proposed infrastructure at the bridge or tunnel approaches;
- ▶ Traffic management during construction.

3.2 DESIGN PARAMETERS

3.2.1 Design speed

The road transport infrastructure under study is part of the major highway network of the Greater Montreal metropolitan region, essentially of the freeway type. In this context, it is reasonable to consider that the actual user travel speed will be from 15 to 20 km/h faster than the posted speed, which is – and will very probably remain – 70 km/h.

For the purposes of this study, BCDE recommends a design speed of 100 km/h. It would be desirable for a travel speed study to be undertaken in a later phase to validate this recommendation.

The strongest effect of this recommendation will be felt in connection with the vertical curve above the seaway, which currently corresponds to a speed of 65 km/h.

3.2.2 Cross section

A primary element to be decided in developing a typical cross section of a roadway is the width of the traveled lanes. Given that this is a freeway segment requiring a design speed of 100 km/h, the design standards of the Ministère des Transports du Québec, as well as those of the Transportation Association of Canada, recommend a width of 3.7 m per traveled lane.

Moreover, modern standards now recommend the presence of a right shoulder – or emergency stop lane – 3.0 m wide on long highway bridges. On the left, the optimum width for 3 lane highways is 3.0 m per direction; however, a minimum of 1.3 m is recommended in urban settings, which corresponds to what exists on most of the highway network in the Montreal region.

As for the space required to install exclusive bus lanes, it must be at least 6.5 m wide per direction if these lanes are separated from each other. If a single corridor is provided for exclusive bus use in both directions, a width in the order of 9 m would be sufficient. Both these minimum dimensions are also more than acceptable for the future installation of a Light Rail Transit system (LRT)⁷.

Because of the total width required in each direction, bridge engineers have indicated that a single deck would be much too wide and so each direction should have its own deck with the same width, with sufficient space between them for inspection and maintenance requirements.

Figure 3-1 illustrates first, in the top part, the cross section recommended for a design with 3 regular traveled lanes plus one Exclusive Lane for Public Transport (ELPT), as suggested in Chapter 3 on traffic needs. Between the regular traveled lanes and the public transport lane, a rather wide barrier (1,050 mm) is proposed to accommodate lighting and sign support structures. This results in a deck 23.82 m wide in each direction; it is interesting to note here that each of these decks would be wider than the current bridge (23.20 m).

A cross section including 4 regular lanes per direction was also drafted (see Figure 4-1, bottom part) for the purposes of comparing the costs of such an option. This cross section provides, in each direction, in addition to the 6.5 m ELPT, 4 regular traveled lanes 3.7 m wide and shoulders of 1.8 m to the right and 1.3 m to the left, for a total of 26.32 m including the barrier and parapets. Accordingly, this option represents, for each of the two decks, a widening of 2.5 m compared to the 3-lane option.

⁷ Later studies for the implementation of a LRT could, after analysis of snow removal and emergency passenger evacuation needs, recommend a smaller width.

Figure 3-1: Typical Cross Sections for 3 or 4 lanes + ELPT per direction

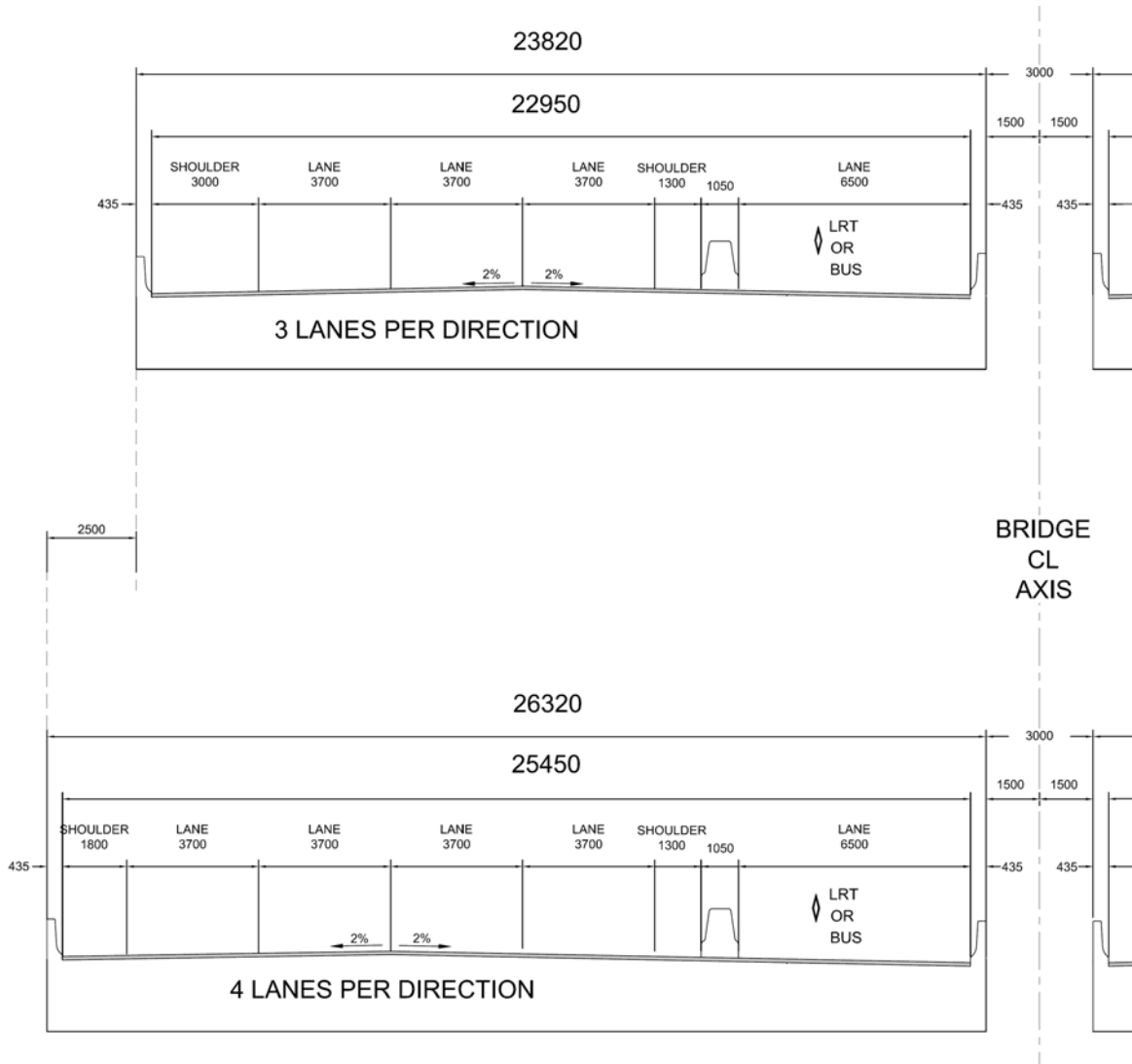

3.3 PROPOSED LAYOUT

3.3.1 Horizontal alignment

It is recommended that the new bridge – or potentially the tunnel option – be located downstream of the existing bridge, for the following reasons:

- ▶ Minimize the impacts of the new alignment on île des Sœurs;
- ▶ Facilitate temporary installations during construction (stabilization and/or anchoring of temporary structures and barges on the existing piers situated upstream);
- ▶ Provide ice protection for the temporary structures.

The new bridge would be located at a minimum distance of 10 metres from the existing bridge, in order to allow sufficient work space for demolition of the existing bridge.

Minimum radii of curvature of 5,000 m would be inserted at each end to limit the intervention zone at the bridge approaches and ensure a clearance of about 3 m from the abutments of the existing bridge. Moreover, the use of radii of 5,000 m or more makes it possible to maintain a normal crown both on the structure and the approaches. Figure 3-2 illustrates the proposed alignment schematically.

Figure 3-2: Location of the New Champlain Bridge

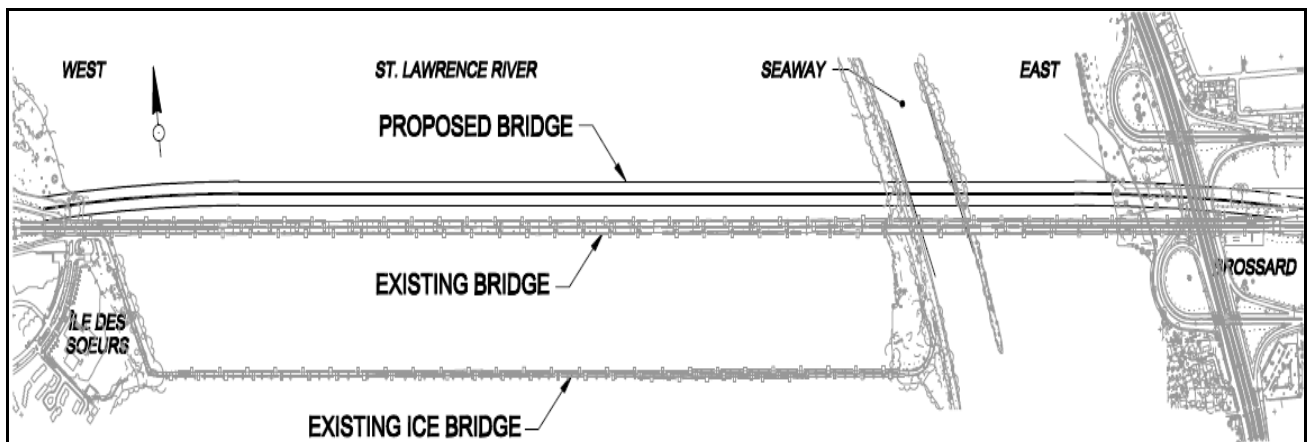

3.3.2 Vertical alignment

Besides the design speed established at 100 km/h and the clearance template above the seaway, the bridge engineers expressed the need to have a circular curve (and not the usual parabolic curve) with a 8,000 m radius to facilitate an eventual launching of bridge sections and also asked that alternative vertical alignments be allowed for deck thicknesses of 4 and 8 m above the seaway clearance template.

The 8,000 m vertical curve radius turns out to provide satisfactory stopping sight distance up to a speed slightly above 100 km/h. As for the influence of the slope on the deceleration of heavy vehicles, the analyses demonstrated first that there was no need to reduce the existing slope of 3.0%, and second that there would be no serious negative effect from increasing it to 3.5%.

It was therefore agreed with the bridge engineers to locate the South Shore abutment – which is the only one to experience the effect of the new profile – at a location that would allow it to be at the same height as the existing abutment (about 9 m) in the worst case (8 m deck and a slope of 3.5%), such that any bridge solution including a deck less than 8 m thick above the seaway would allow a slope of less than 3.5%.

3.4 EXCLUSIVE LANE FOR PUBLIC TRANSIT

The insertion of separated roadways dedicated exclusively to public transit (ELPT) on the Champlain Bridge – whether for a Light Rail Transit system (LRT) or a Bus Rapid Transit system (BRT) – implies that this infrastructure is also extended and/or connected to similar installations at either end of the bridge.

On the South Shore, a dedicated bi-directional roadway for buses already exists in the median of Highway A-10, an arrangement that could easily be adapted for a future LRT, as proposed in the 2004 AMT study. It would be very simple to connect it from near the Provencher St. structure to the ELPT lanes of the new bridge, also planned for its centre, as analysed and estimated within the present study.

On the Montreal side, however, such a connection is less obvious because there is no infrastructure of this kind yet present. Two options were analyzed in detail, depending on whether an LRT or BRT is considered.

Figures 3-3 and 3-4 offer summary illustrations of these two options. The LRT option would first include a station in the middle of Highway A-15 on Île des Sœurs and then follow the route proposed by the AMT in 2004, crossing the arm of the St. Lawrence between Île des Sœurs and the island of Montréal. It is to be mentioned that this LRT option could be used for a BRT system in a first phase, provided that very minor adjustments are made.

The BRT option, on the other hand, would remain in the middle of Highway A-15 until west of the Île des Sœurs Bridge, where it would reach the existing Bonaventure Expressway via an underpass under the northbound lanes of A-15, thereby eliminating the existing traffic light. Access lanes from and to René-Lévesque Blvd. would allow STM buses to use these dedicated lanes to service Île des Sœurs.

Cost of the LRT option, for the section comprised between the west abutment of the future Champlain bridge and its connexion on the Montréal Island, is estimated at about \$55 million in

2010 dollars (excluding the station, terminal and parking lot, as well as professional fees), while the cost of the BRT option, for the portion of the ELPT structure within the same limits as above, is estimated at between \$63 and \$66 million (with the same exclusions, as appropriate), depending on the type of structure selected for replacing the Île des Sœurs Bridge; these estimated values for the BRT option include a \$9 million reserve for the removal of 100,000 m³ of contaminated soils on the Montréal Island.

Figure 3-3: Route of the LRT option

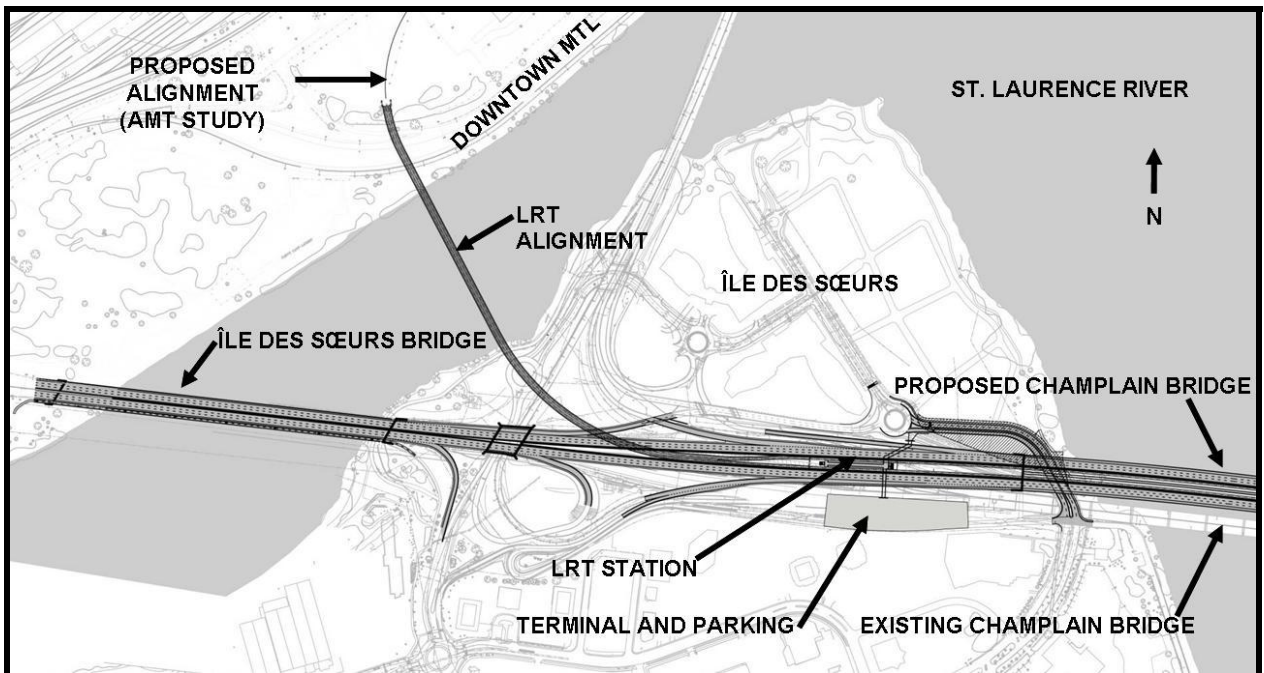
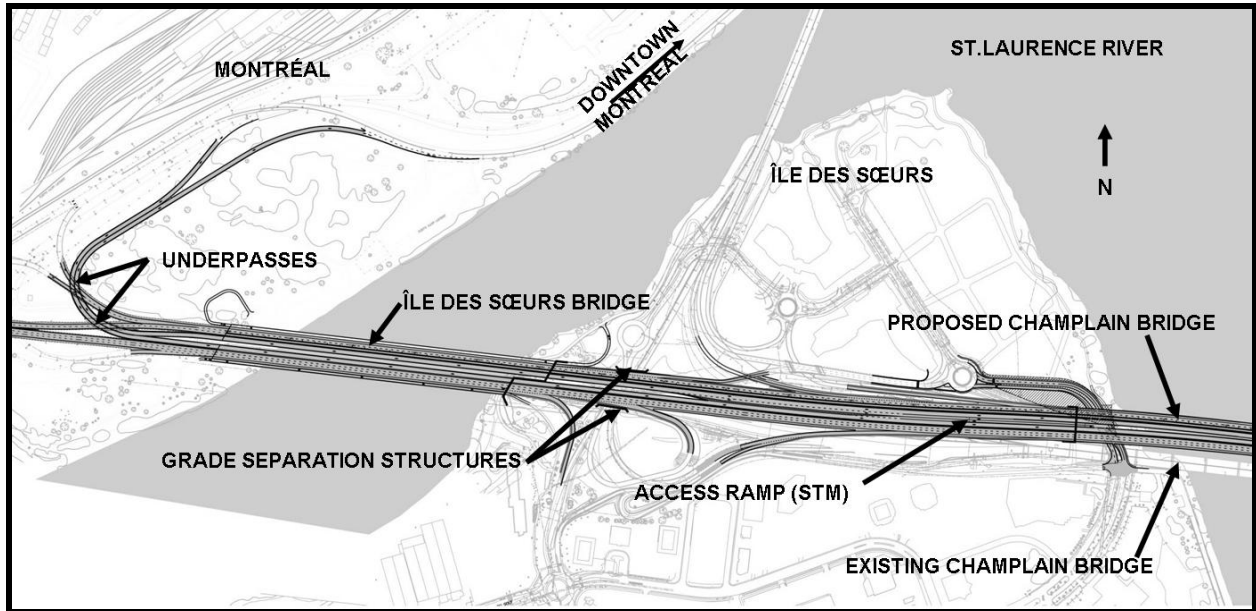

Figure 3-4: Route of the BRT option



3.5 ASSESSMENT OF IMPACTS

3.5.1 On existing infrastructure

The alignment of the new bridge was designed in a way to maintain the existing infrastructure wherever possible. However, certain adjustments, relatively minor given the scope of this project, are necessary:

- ▶ On île des Sœurs:
 - Relocation René-Lévesque Boulevard over a length of about 300 m,
 - Adjustment of a traffic circle (roundabout),
 - Displacement of some 80 m of the bicycle path.
- ▶ On the South Shore:
 - The entrance and exit ramps to/from the new bridge will require some improvements and adjustments, especially the merging curves and acceleration and deceleration lanes.

3.5.2 On land acquisitions

On île des Sœurs, the work will take place essentially on the north side of the existing highway; relocation of René-Lévesque Boulevard requires acquisition of about 8,000 m² of property not yet developed.

For crossing the St. Lawrence River, the new alignment is obviously outside the current right-of-way or servitude of JCCBI; this should not however cause a major problem.

Finally, on the South Shore, the proposed work will take place entirely on public land, belonging either to the MTQ (rights-of-way of the Highway 132 interchange or Autoroute 10), or the Ville de Longueuil (between the shore of the river and Highway 132).

3.5.3 On public services and utilities

In the île des Sœurs sector, the zone affected is René-Lévesque Boulevard between the roundabout and the existing Champlain Bridge. The public services and utilities affected (sanitary sewers, storm sewers, water distribution, underground telephone and electrical cables, natural gas pipeline, duct banks for electrical and telephone cables) are located below the future bridge abutment and under the approach fill. They will therefore have to be moved along the new alignment of René-Lévesque Boulevard.

As for the South Shore, the major element involves moving about 650 m of Hydro-Québec 315-kV high voltage line that follows the northern side of the approach to the Champlain Bridge; more specifically, this displacement involves moving 2 pylons laterally about 25 m northward.

3.5.4 On environment

Like the existing bridge, the new proposed alignment of the Champlain Bridge crosses three spawning grounds. In addition, this alignment also crosses a known site of an archaeological interest located on Île des Sœurs.

On the South Shore, minor visual and noise impacts will result from bringing the highway⁸ some 60 m closer to housing located northeast of the Highway 132 interchange and raising the highway about 4 m above Highway 132.

⁸ Distance between the closest house and the A15/R-132 grade separation structure.

3.5.5 Traffic management during construction

At this stage of development and for the purpose of this study, a summary analysis of traffic management during construction was conducted and the following principles were adopted as the basic premise for the analysis: six traffic lanes would be maintained during the peak periods, the existing roadway widths would be kept in order to preserve the operation of the reserved bus lane, and access to the municipal and highway networks would be maintained. The analysis made it possible to determine that it is possible to respect these principles when constructing the new replacement structure for the existing bridge; this type of traffic maintenance is rather conventional and has been amply proven in the past.

4 BRIDGE SOLUTIONS

The overall solutions proposed for the replacement of the existing Champlain Bridge by a new bridge stem from the integration of possible solutions for each section of the structure, i.e. the seaway crossing and the river crossing. The seaway crossing must reflect the very restrictive calendar constraints for construction and operating constraints that are not yet completely defined; it requires a span of at least 200 m and a vertical clearance of at least 37.50 m. The optimum length for the spans crossing the river has been fixed at 80 m, which is nearly 50% longer than existing standard spans (53.75 m), thereby eliminating one pier in three.

Construction methods were a decisive factor in developing structural design concepts. The methods considered for crossing the Seaway are the following:

- ▶ Hoisting the central span, in one or more segments;
- ▶ Launching the framework;
- ▶ Construction by successive cantilivers;

For crossing the river, the construction methods considered are:

- ▶ Erection with a launching truss;
- ▶ Launching the framework;
- ▶ Erection with a crane.

Preliminary analyses by BCDE resulted in the proposal of 5 solutions for the construction of a new Champlain Bridge:

- ▶ Pre-stressed concrete box girder bridge;
- ▶ Hybrid Steel-concrete bridge;
- ▶ Composite steel-concrete bridge for superstructure (concrete deck supported on a steel structure);
- ▶ Composite steel-concrete bridge superstructure with V-shaped piers on each shore of the seaway;
- ▶ Cable-stayed bridge with composite deck.

4.1 COMPARATIVE ANALYSIS

Table 4-1 presents the main advantages and disadvantages of each of the 5 proposed solutions. Appendix 1 contains elevations and cross sections of these solutions.





At this pre-feasibility study stage, it was considered inappropriate and unwise to reduce the number of potential solutions relating to the type of bridge. In fact, in a context of constraints that are highly

complex and to some extent still not fully defined, it would be premature to eliminate interesting options without having analyzed them in greater detail in a preliminary engineering phase. The questions as yet unresolved regarding the construction over the seaway are: the authorities of the St. Lawrence Seaway Management Corporation (SLSMC) have not yet responded to the questions addressed to them in March 2010 about the possibility of relaxing the very restrictive condition which would allow work over the seaway only during the winter period when the seaway is closed, namely from January 1 to February 15.

In addition to the studies normally required to pursue the development of a project of this scale (geotechnical investigations, bathymetrical surveys, hydraulic and ice-flow studies, environmental impact and terrain modelling, etc.), there should also be some special studies, including:

- ▶ Risk assessment with respect to construction work over the seaway;
- ▶ Traffic live load studies (truck loading model, special permit overloads, LRT) applicable for a bridge of this length and design life.

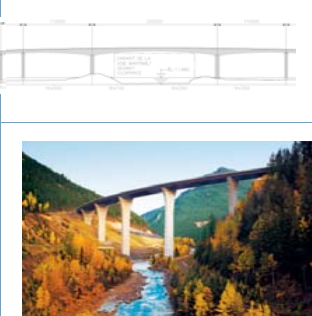
Table 4-1 – Comparative analysis of the “bridge” solutions

CRITERIA	PRESTRESSED CONCRETE BOX GIRDER	HYBRID STEEL-CONCRETE	COMPOSITE	COMPOSITE WITH V-SHAPED PIERS	CABLE-STAYED WITH COMPOSITE DECK
Image *					
Length / width	Total length = ±3 500 m. Seaway span = ± 200 m. Regular spans = ± 80 m. Total width = two 23.82 m decks				
Description – Seaway	Single box of prestressed concrete cast on site and built by balanced cantilever method.	Combination of a concrete and steel bridge: central portion of the main span in steel, embedded in concrete spans.	Composite steel-concrete superstructure of variable height.	Composite superstructure with V-shaped piers reducing the length of the main span above the seaway.	Cable-stayed bridge composite deck with a single tower.
Description – regular spans	Prefabricated concrete box girders.	Prefabricated concrete or composite superstructure.	Composite steel-concrete superstructure of constant height..	Composite steel-concrete superstructure of constant height..	Composite steel-concrete superstructure of constant height..
Construction constraints	Short repetitive periods of work above the Seaway.	Seaway closed during hoisting of main span	Short repetitive periods of work over the Seaway (concreting of slab). A closed box-girder solution reduces/eliminates the corresponding constraints.	Short repetitive periods of work over the Seaway. A closed box-girder solution reduces/eliminates the corresponding constraints. When main span is hoisted, Seaway operation is halted.	Short repetitive periods of work over the Seaway. A closed box-girder solution reduces/eliminates the corresponding constraints. When main span is hoisted, Seaway operation is halted.
Construction cost (with contingencies)	830	895	775 for twin-girders 910 for boxes	910	910

CRITERIA	PRESTRESSED CONCRETE BOX GIRDER	HYBRID STEEL-CONCRETE	COMPOSITE	COMPOSITE WITH V-SHAPED PIERS	CABLE-STAYED WITH COMPOSITE DECK
Operating and maintenance cost	Different problems but solutions are overall equivalent				
Construction time	Equivalent solutions at this stage of the studies.				
Environmental effects	Minimal effects: number of piers is reduced compared to current number				
Aesthetics / Visual effect	Basic solution	Basic solution	Basic solution	Signature solution	Signature solution
Ramps	East approach ramp: visual and noise disturbances from moving the alignment north, near the residential sector, and rather pronounced rise of longitudinal profile.				
Advantages	Less variability in concrete price. Improved quality due to prefabrication.	Light deck, reduction of loads on foundations for regular spans.	Light deck, reduction of loads on the foundations	Light deck, reduction of foundation loads. Reduction of main span, allowing launching from just one side. Good visual effect.	Light deck, reduction of loads on the foundations. Good visual effect.
Disadvantages	Monolithic section makes serious repairs very complex.	Delicate construction of the connections between metallic and concrete sections.	Launching from both sides required	Complex construction of V-shaped piers	Complex construction due to the cables

*: Appendix 1 provides larger elevations and cross-sections of these 5 solutions.

5 “TUNNEL” SOLUTIONS

This sub-section of the prefeasibility study is intended to better define the problems and issues involved with replacing the Champlain Bridge by a tunnel.

The development of the “tunnel” options within the context of this study took place in two successive steps:

- ▶ Part A, *Enumeration of possible alternatives*, compared the various alternatives for replacing the existing Champlain Bridge with a tunnel infrastructure. Stemming from the analysis carried out under Part A work, one solution was selected and reported, and further developed under Part B.
- ▶ Part B, *Development of the selected solution*, provided a more detailed analysis of the preferred tunnel solution.

5.1 ENUMERATION OF POSSIBLE ALTERNATIVES

In this first part of the study, four solutions were examined:

- ▶ Two bored tunnel solutions,
- ▶ One shallow sub-river tunnel solution involving two possible construction methods.

5.1.1 Bored tunnel solutions

The bored tunnel solutions, because of their great depth below the riverbed, do not allow restoring the interchanges on Île des Sœurs or with the Bonaventure Expressway and Highway 132. The connections at the tunnel ends are very complex and have a very large impact on property and many buildings will have to be acquired and demolished. Land-use control constitutes a major risk in terms of cost and time.

Construction of an underground station for the reserved lane public transit on Île des Sœurs is possible, with access being provided by a shaft and elevators and/or escalators.

Both solutions use tunnel boring machines (TBM):

- ▶ Alternative A includes two bored tubes some 17 m in diameter and two superimposed levels. In each tube, the upper level is dedicated to three lanes of road traffic, while the lower level is dedicated to one of the two exclusive lanes for public transit (ELPT) and an evacuation route for users (see Figure 5-1). Users are evacuated by chutes linking the upper level to the evacuation route. The dimension of the required TBM is close to the limit of current technologies.

Figure 5-1: Typical Cross Section, Alternative A

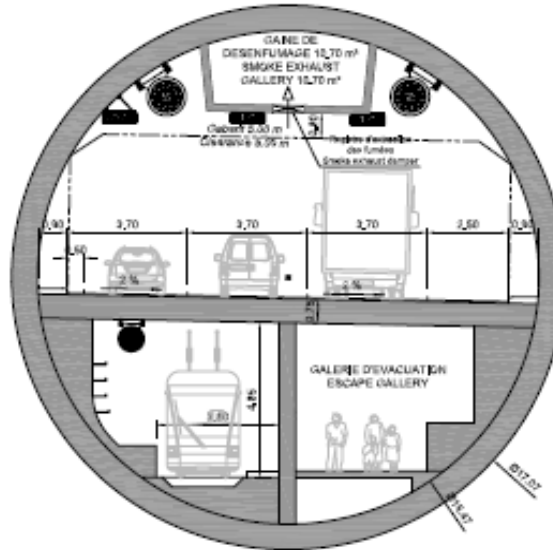

- ▶ Alternative B contains four bored tubes, linked by transversal galleries, which allow evacuation from one tube to another, as shown in Figure 5-1. In each travel direction:
 - One tube, 14.60 m in diameter, dedicated to light vehicles on four lanes, divided on two levels;
 - One tube, 12.64 m in diameter, dedicated to heavy vehicles and ELPT, on rails or tires.

Figure 5-2: Typical Cross Section, Alternative B

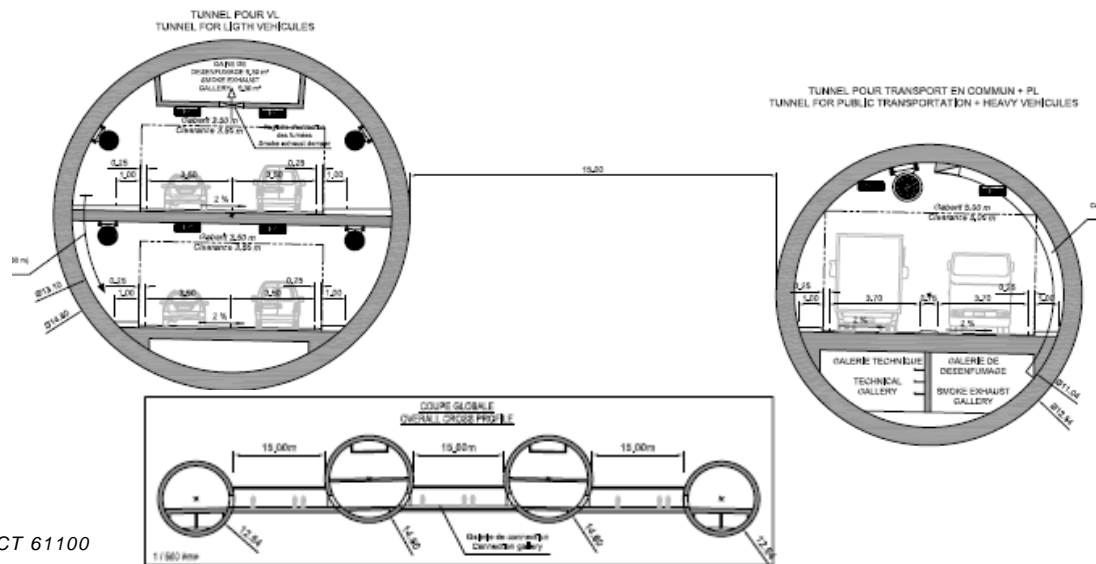

CT 61100

PRE-FEASIBILITY STUDY OF THE REPLACEMENT OF THE EXISTING CHAMPLAIN BRIDGE - SUMMARY REPORT, MARCH 31, 2011

Ventilation of the tunnels is assured by longitudinal ventilation with ceiling accelerators. The air is taken from both exits as well as from a shaft located on Île des Sœurs.

In the event of a fire, the smoke is aspirated by way of motorized, remote-controlled flaps, then by an exhaust duct located either in the vault or below the traffic zone. The smoke is vented at the tunnel exits or on Île des Sœurs through a ventilation plant on each of the sites and small chimneys allow its dissemination.

Evacuation of users in the event of fire is assured:

- ▶ For alternative A: i) by chutes connecting the roadway and the escape gallery – ii) by direct level links to the escape gallery, through fire doors for users of the ELPT. Evacuation is then assured toward to tunnel exits or by a specific access located in the Île des Sœurs shaft.
- ▶ For alternative B: evacuation between the upper and lower level of the tube reserved for light vehicle (LV) traffic is provided by chutes. Evacuation between the lower level of this LV tube, and the RLPT and HW (heavyweight) tube and vice-versa is provided by junction galleries between the tubes. Evacuation then occurs by a sound tube from which traffic has been removed, either in the direction of the tunnel ends or toward the Île des Sœurs shaft.

5.1.2 Under-river tunnel solutions

The shallow tunnel solution, built either by immersion of prefabricated caissons or traditional dry methods in an enclosure protected by a cofferdam, makes it possible to maintain all existing interchanges and services on the shores as well as on Île des Sœurs.

The standard cross section is identical for both these solutions. It contains (see Figure 5-3):

- ▶ Two sub-spaces dedicated to road transport with 3 travel lanes for each traffic direction,
- ▶ One sub-space with two traffic lanes (one in each direction) for the ELPT,
- ▶ Two evacuation galleries for users in case of fire.

Ventilation is provided by a longitudinal ventilation system with accelerators placed in the ceiling. Evacuation of smoke in case of fire is provided through remote-controlled motorized flaps and two exhaust galleries placed above the escape galleries.

Evacuation of road or ELPT users is provided by the two evacuation galleries via fire doors spaced at 100 m.

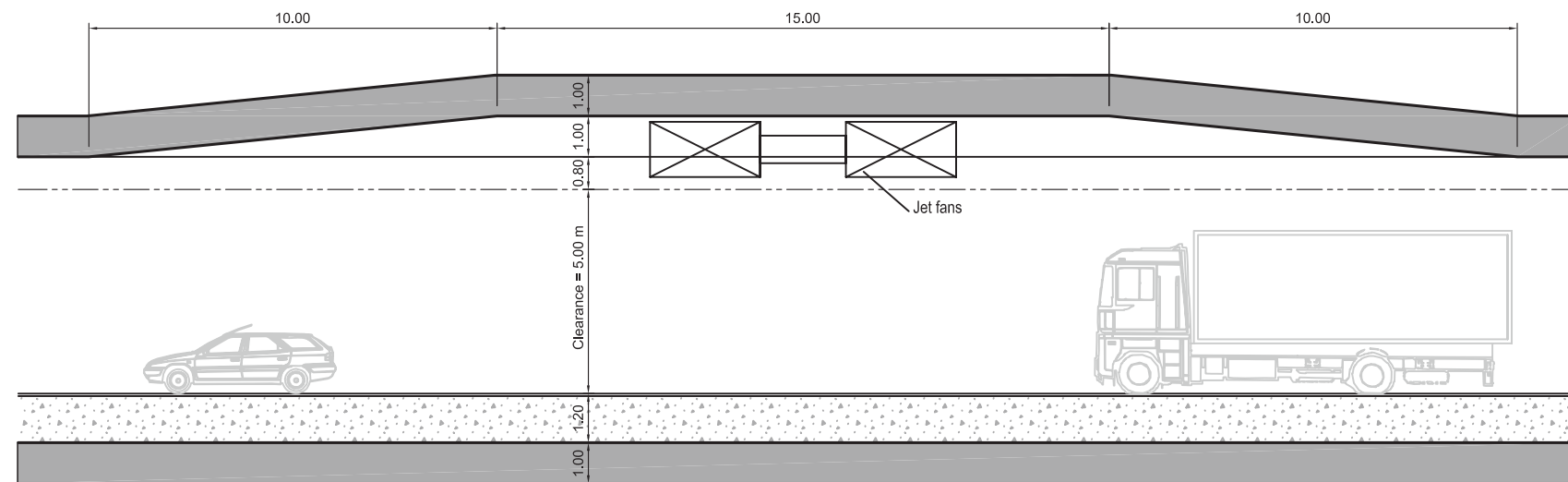
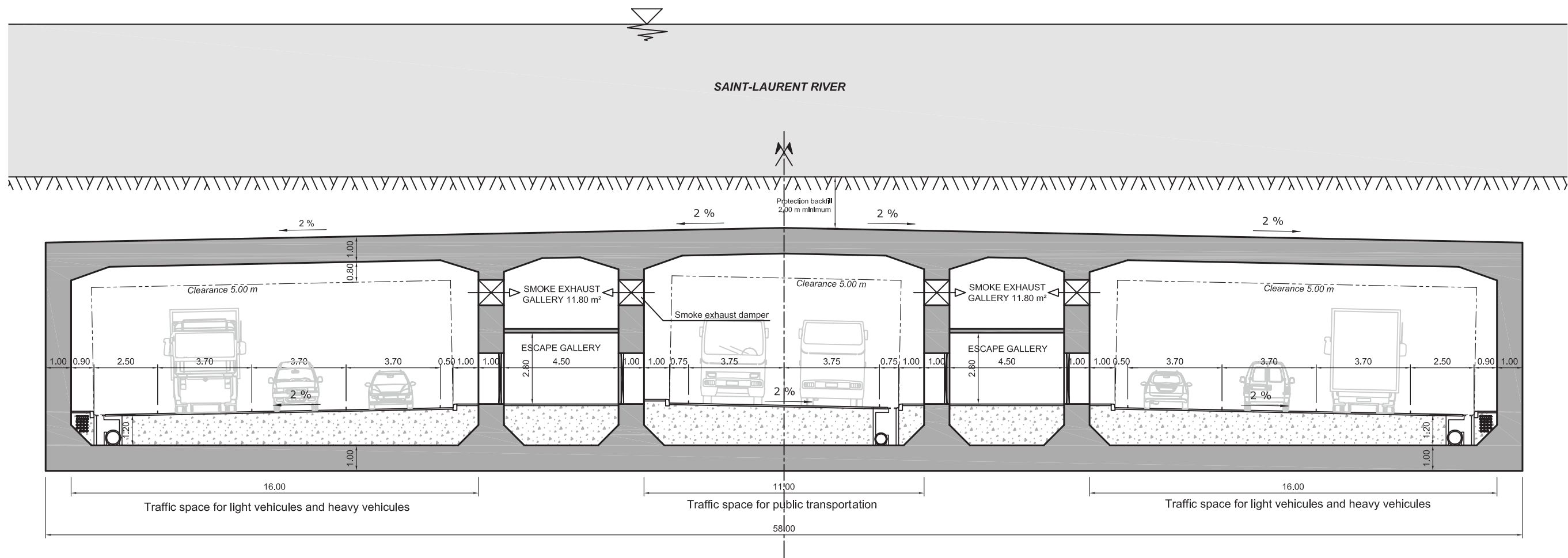

IND.	DATE	MODIFICATION	VB	VB	BF
0	21/01/01	Édition du document	VB	VB	BF
			Designed	Drawn	Checked

Figure 5.3 - ALTERNATIVE IMMERSSED TUNNEL

5.1.2.1 *Construction using immersed caissons*

The construction method using immersed caissons consists of:

- ▶ Prefabricated tunnel sections in the order of 100 in length in a dry dock,
- ▶ Flooding the dry dock so that the prefabricated elements will float,
- ▶ Transporting them by floating to where they will be installed, then immersing them with ballast in an excavation on to foundation blocks installed in advance.

The characteristics of the bed of the St. Lawrence, especially the low draft, require having a large dock in the immediate vicinity of the structure and carrying out excavation to provide adequate draft which is indispensable for transporting the elements.

Because of the large size of the space necessary and access requirements, this dock could only be built in the extension of the northern point of Île des Sœurs by encroaching in the bed of the St. Lawrence. In fact, this zone is very sensitive ecologically, and the construction of such a dock would result in the destruction of the terrestrial and aquatic ecosystem in this area.

5.1.2.2 *“Dry bed” construction behind cofferdams*

The “dry bed” construction method within an enclosure protected by cofferdams has much less impact on the environment. Moreover, this impact can be minimized by job site flexibility in relation to annual sensitive periods as well as by the much shorter time for coastal engineering water works, with all access to the work site occurring over a land route using the tunnel section already built. This solution has a rather low impact on the flow of the St. Lawrence. The layout considered would result in building cofferdams equal to 10% of the width of the river between Île des Sœurs and the seaway dike.

The Seaway crossing on the right shore can only be executed using the immersed tunnel method because of the very short annual periods during which marine traffic is halted. Three winter periods would be required to complete the work.

5.1.2.3 *Environmental Impact*

Construction using the cofferdam method is less harmful to the environment than the immersed tunnel method. This is due essentially to:

- ▶ elimination of the Île des Sœurs dock and destruction of the aquatic habitats that it would cause in an environmentally sensitive zone,
- ▶ the substantial reduction of marine works, especially underway earthworks. The materials are extracted dry in industrial operating conditions. This makes it possible to avoid polluting the water by suspended fine particles. Excess waste materials removed in dry conditions can be removed from the work site without risk of marine biofouling of the routes used.

5.1.3 Construction costs and periods

The construction periods were not examined in detail in this first step. Construction times for bored tunnels using tunnelling machines are the longest, given the machine construction time, and then their re-use from tube to tube.

Construction costs vary significantly from solution to solution. The bored tunnels are penalized by the length of the structures and the very large impacts in the connection zones. The immersed tunnel solution is penalized by the size of the Île des Sœurs dock and volume of marine works, in particular the underwater earthworks.

Figure 5-4 presents the relative costs of the four solutions, with the under-river tunnel built inside cofferdams taken as the reference base.

Figure 5-4: Comparison of construction costs

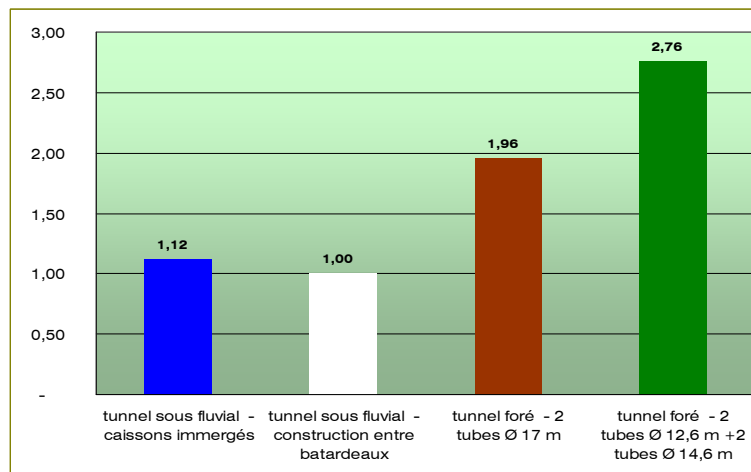

5.1.4 Comparative table of tunnel solutions

Table 5-1 summarises the main comparative criteria of the four analyzed solutions. The rating of each of the solutions is represented by a “colour code” defined as follows:

green = favourable **yellow** = barely favourable **red** = unfavourable **black** = very unfavourable.

This table reveals the advantage of the shallow tunnel built between cofferdams. A typical section of this solution was presented in Figure 5-3. The amounts appearing in the Table are expressed in millions of dollars before taxes. They do not include:

- ▶ the “contingency amount” (financial provision in the order of 25% at this stage of the studies),

- ▶ specific complementary studies: soil investigations, laboratory tests, topographic and bathymetric surveys, ice studies, Hazardous Materials Transport studies and investigations, detailed environmental studies,
- ▶ material quality controls,
- ▶ archaeological digs,
- ▶ environmental compensations.

5.1.5 Retained solution

Based on this first set of studies, it was decided to select the under-river solution built in dry conditions within cofferdams for further review and development.

This solution allows restoring all the existing connections and interchanges on the right shore (south shore) of the St. Lawrence River and on Île des Sœurs. This is the most economical solution and the one that is least intrusive from the environmental and sustainable development perspective. This construction method is quite flexible and allows good adaptation to the various constraints, i.e. climatic, environmental and those resulting from operation of the Seaway.

Table 5-1: Comparative multicriteria analysis of “tunnel” solutions

CRITERIA	SUB-RIVER SUBMERGED CAISSONS	SUB-RIVER BETWEEN COFFERDAMS	BORED, - 2 TUBES	BORED, - 4 TUBES
Length	3,730 m tunnel + cut-and-cover	3,730 m tunnel + cut-and-cover	6,960 m tunnel + cut-and-cover	6,960 m tunnel + cut-and-cover
Number of lanes	2 x 3 + 2 exclusive transit lanes – 4th lane possible	2 x 3 + 2 exclusive transit lanes – 4th lane possible	2 x 3 + 2 LRT lanes– 4th lane impossible	2 x 4 auto + 2 truck + 2 bus or LRT
Interchanges and connections	All existing connections and interchanges maintained	All existing connections and interchanges maintained	No connexions with R-132, Île des Sœurs and Bonaventure highway	No connexions with R-132, Île des Sœurs, and Bonaventure highway
Impacts on Land and buildings	No impact	No impact	Strong impact in connection zones	Very strong impact in connection zones
Hydraulic impact	Low impact– underwater work	Moderate impact due to cofferdams	None	None
Impact on aquatic habitat	Very strong: risk of water pollution – spawning grounds in the dock area	Moderate: cofferdam and foundation construction	None	None
Direct construction costs	1,540 M\$	1,370 M\$	2,680 M\$	3,780 M\$
Technical complexity of construction	Tested method (at L.-H.-La Fontaine tunnel) – limited competition	Cofferdams in the riverbed	2 very long tubes– diameter at the limit of the TBM technology	4 tubes + complexity of connections
Operating costs	Average: Single block unit of average length	Average: Single block unit of average length	High: 2 large independent and very long tubes	Very high: 4 independent and very long tubes
Traffic impacts during construction	Limited short-term local detours	Limited short-term local detours	Long-term detours in the connection zones	Very long-term detours in the connection zones
Relocation of public utilities	No major utilities noted	No major utilities noted	Major utilities on left shore	Major utilities on left shore
Acceptability	Impact of the dock and earthworks in the riverbed	No major impact	Numerous expropriations – connexions impossible with Île des Soeurs, Bonaventure Expressway. and R-132	Numerous expropriations. Connexions impossible with Île des Soeurs, Bonaventure Expressway and R-132
Overall appraisal	Barely favourable	Favourable	Unfavourable	Very unfavourable

5.2 DEVELOPMENT OF THE RETAINED SOLUTION

This second part of the study involved a more detailed analysis of the main elements of the selected solution of 2 x 3 traffic lanes and + 2 lanes for a ELPT. A typical cross section of this solution appears above in Figure 5-3.

In parallel with these analyses, two other options were also considered and evaluated : one option containing a carriageway with 2 x 4 lanes instead of 2 x 3 lanes, and another offering a 2 x 3 lane platform without any ELPT..

5.2.1 Main elements

5.2.1.1 *Horizontal alignment and longitudinal section*

The concepts and assumptions used in the preliminary analysis were confirmed, refined and improved.

- ▶ The tunnel is still located upstream of the Champlain Bridge.
- ▶ The alignment was slightly offset to improve the geometry, optimize the connections and better reflect the construction methods, and the space necessary for moving the marine work machinery for construction and moving the cofferdams,
- ▶ The longitudinal section was optimized with the triple objective of:
 - reducing the slopes – improving the capacity of the structure– optimizing the operating costs,
 - optimizing construction costs,
 - better accommodation to the construction methods, in particular for crossing the Seaway.

The length of the tunnel is 3,610 m. It is extended by a funnel of 120 m on the right shore, and a funnel of 100 m on Île des Sœurs.

5.2.1.2 *Connections and Interchanges*

The highway connections to the west and east, as well as the redesign of the interchanges on both shores of the St. Lawrence were analyzed, and the layout and longitudinal sections studied.

The feasibility of these connections and interchanges, in conditions similar to those that exist today, was confirmed, if the necessary adaptations are made. On the right shore:

- ▶ The radius of the entrance ramp from the R-132 to the tunnel was reduced to 58 m,
- ▶ As a result, the radius of the exit ramp from the tunnel to the R-132 was increased to 108 m.

All current traffic and interchanges were kept in the final concept and are kept in operation throughout the works, except for a very short interruption of the entrance ramp from Île des Sœurs to the tunnel, and the exit ramp from the tunnel to R-132. The corresponding work can only

actually be completed after the tunnel is commissioned. Detours can be arranged without major difficulty, however.

5.2.1.3 *Functional section*

The functional section is unchanged, except for the two escape galleries that it was necessary to enlarge to 5.25 m (instead of 4.50 m) in order to provide transverse section necessary for the smoke exhaust galleries (see Figure 5-3).

This change results from pre-sizing the ventilation installations and in particular optimizing the losses of aerodynamic loads.

5.2.1.4 *Civil engineering structures*

The sizing of the civil engineering structure is confirmed for the typical section, with a thickness of 1.00 m of prestressed concrete.

A reinforced structure was created for the sectors of the greatest coverage, under the Seaway, the dikes and under the provisional cofferdams. The thickness of the slabs as well as that of the exterior walls has been increased to 1.50 m.

The structure is prestressed longitudinally (lower slab, upper slab, exterior walls), transversally (lower slab, upper slab) and vertically (exterior walls).

The soffit of the traffic spaces as well as of the ventilation shafts is lined with thermal protection that is intended to protect the prestressed concrete structure during a fire. The thickness of this protection (on the order of a decimetre) has not been sized precisely at this preliminary study stage, because it is necessary to carry out 3 D simulations of various fire scenarios, in order to determine the temperature to which the structure soffits are exposed, and the duration of this exposure.

5.2.1.5 *Ventilation installations*

The ventilation installations were pre-sized for the sanitary ventilation conditions, as well as for a fire with a power of 50 MW. The scenario of a 200 MW fire was also examined.

The concepts of the initial study are confirmed. The ventilation installation contains:

- ▶ ceiling accelerators (housed in blisters) to ensure continuous ventilation of the traffic spaces and to manage smoke confinement during a fire,
- ▶ two smoke exhaust galleries equipped with three exchange fans installed in the plants installed on each of the two exits. These three fans are common to both galleries: two operating fans and one back-up fan. The smoke is evacuated through a vent installed on each of the two tunnel exits,

- ▶ two fans (one on each exit) to introduce fresh air into the escape gallery and to provide a slight overpressure to avoid the penetration of smoke when the emergency exit doors are open for users leaving the tunnel during a fire.

5.2.1.6 *Operating and safety installations*

The operating and safety installations are described and partially pre-sized to allow definition of the functional diagrams of the technical facilities and tunnel exit buildings.

A ventilation plant and technical facilities including the electrical stations, medium voltage, low voltage and low currents are installed on each of the two exits.

This building is further complemented on the Île des Sœurs exit by a control and supervisory station as well as a maintenance, repair and service centre.

5.2.1.7 *Preliminary approach to safety and THG features*

The safety issues have been analyzed in a more detailed way for the “tunnel” solution, and the various features for safety equipment, evacuations and access to services have been confirmed. It should be kept in mind that the “bridge” solution and the neighbouring sections in open air upstream and downstream of the structures are not free of risks associated with the *transport of hazardous goods* (THG). A serious THG accident can in some cases be more critical outside the tunnel than in the tunnel, where the ventilation system in fact makes it possible to control the spread of toxic fumes and protect users located nearby.

The problem involving THG was analysed based on information contained in the report on THG traffic in the Montérégie area. The THG traffic is relatively light and more or less divided among the various crossings, depending on the products carried, their origins and destinations. This analysis suggests possible solutions, compatible with tunnel travel and operation, and the level of security required. These solutions are based on:

- ▶ better allocation of flows according to the actual types of products transported,
- ▶ traffic restrictions,
- ▶ a regulation of THG through the tunnel, associated with the hourly traffic flow and time of day.

A scenario of a 200 MW fire was analyzed. It suggests very limited and controllable risks, to the extent that this fire occurs outside high traffic periods.

This preliminary and limited analysis of THG transport must be taken further should this solution be retained, and this would require a broader survey, a 3D modeling of a 200 MW tunnel fire, analysis of the origins and destinations by the nature of the products transported, the listing of potential alternative routes and the risks these itineraries may present in case of a transfer of a portion of the THG traffic.

5.2.1.8 Construction methods

The concepts of the construction methods presented in the preliminary study were analyzed in detail, the construction phasing clarified and the temporary structures, such as the cofferdams, were presized.

Three construction modes were considered:

- ▶ A conventional mode for the structures on land,
- ▶ Dry construction within an enclosure protected by cofferdams for the river crossing under the St. Lawrence.
 - These cofferdams are made of floatable metal boxes, immersed in place by ballasting with sand, on the site where they will be used. The waterproofing, stability, floatability, removal and transfer arrangements were the subject of a detailed study and are presented in the report,
 - The flexibility of the proposed methods and their implementation, the absence of earthworks in the river, also help satisfy environmental constraints,
 - All the work is done in dry conditions within the enclosure, and all transport is provided by land, using the tunnel section already built, installed in the water below the bed of the St. Lawrence.
 - The dimension of the cofferdams was limited to 410 m for the purposes of this study because a detailed hydraulic study was not available. This dimension, which has a significant impact on the execution time, will have to be optimized and, if needed, modulated according to the seasons (flood risks and occurrence) following the detailed hydraulic study.
- ▶ A mixed form of execution for the Seaway crossing and the adjoining body of water:
 - The adjoining body of water is crossed by construction within cofferdams,
 - The tunnel section under the Seaway, some 305 m long, is built using the technique of immersed prefabricated caissons. The excavation below the Seaway is carried out in the water during the annual periods when navigation ceases, using mechanical means (dredging of unconsolidated soils, milling extraction of schist). The caissons are built on dry land in a dry dock arranged by reusing the cofferdam enclosure installed to build the tunnel section under the adjoining body of water. This arrangement, which limits the impact of the work site on the environment, results in adopting special arrangements: (i) reduction to 102 m of the length of each of the 3 caissons – (ii) addition of floaters to allow the transport of these elements, given that the draft is reduced to 9.0 m by the presence of the prior tunnel section prebuilt in place,
 - The proposed methods are very flexible, non-intrusive and could be partly performed during the daily periods of low marine traffic.

5.2.1.9 *Provisional work plan*

The provisional work plan indicates a period of 59 months from the beginning of the preparatory period. This plan takes into account winter interruptions, environmental constraints from suspension of work in the river and the period in which work is prohibited within the right-of-way of the Seaway.

This time period is likely to be optimized to the extent that the length of the cofferdams could be increased and where a certain amount of work that is not intrusive and is compatible with marine traffic and its safety could be conducted outside the periods when the Seaway is closed to navigation.

5.2.1.10 *Construction and operating costs*

The estimated amount for construction work amounts to \$1,907 million before taxes in 2010 dollars. This amount contains a contingency of 25%, estimated expenses for land acquisitions and moving existing public utilities, as well as the project supervision and contracting authority costs, supplementary studies contemplated in 5.3, the work supervision and material control services, as well as environmental compensation costs.

Operating expenses are broken down into:

- ▶ annual operating and regular maintenance expenses, estimated at \$7,920,000 before taxes in 2010 dollars,
- ▶ major maintenance expenses, which occur starting with the tenth year after the structure is commissioned, excluding the creation of an inventory of spare parts, which occurs the first year. The initial creation of this inventory and its update are included in major repairs. The same applies to the upgrading of the installations at the end of the defined period of the financial analysis.

5.2.2 **Options**

One option concerning a tunnel with 2 x 4 road lanes plus 2 lanes for ELPT was analyzed. It implies additional cost of \$48.5 million before taxes in 2010 dollars and 5% higher annual operating costs.

The tunnel option with 2 x 3 lanes without ELPT was also analyzed. The savings in construction costs is estimated at \$257 millions.

Transit of THG would mean a very marginal additional investment cost in the order of 1%.

The presence at the West exit of the tunnel of a service centre for firefighters and equipping it with material specifically for tunnel firefighting is probably indispensable, with or without THG. The corresponding investments cannot be evaluated at this stage of the studies. They could only be

evaluated after completing a study concerning risks and dangers, which will also allow an analysis of the resources and equipment necessary for fighting a fire, with or without transit of dangerous materials.

5.3 RECOMMENDATIONS

This prefeasibility study was prepared on the basis of the information available at this time. This information was occasionally inadequate to execute detailed studies, but this does not hinder the feasibility of the tunnel solution built between cofferdams.

The main complementary information for the development of a tunnel solution are presented in the sector Report no. 05. They involve in particular:

- ▶ List of the affected public utilities and conditions for moving a few towers of the high tension power line located on the south shore of the St. Lawrence River,
- ▶ Detailed topographic plans and terrain modelling of the zone covered by the study and a detailed bathymetry of the bed of the St. Lawrence,
- ▶ Detailed hydraulic studies and ice flow studies,
- ▶ Geotechnical studies: reconnaissance surveys, field and laboratory tests,
- ▶ Survey of THG, safety and danger studies, alternative itineraries. Failing the existence of a Canadian standard for this type of study, it is recommended that they be conducted based on procedures and regulations of the European countries that are most advanced in this field.

6 THE FUTURE OF THE EXISTING STRUCTURES

6.1 The ice structure

The Ice Control Structure, built in 1965 just upstream from the Champlain bridge, is capable of being used for a light rail transit (LRT) system, despite its “advanced age.” With only a few exceptions, the Ice Control Structure has never been used as an actual bridge, and it has aged relatively little, compared to other civil engineering structures of the same age in the Montréal region. An investment in the order of \$170 million would allow transformation of the existing structure into an LRT bridge crossing the Seaway and reaching the South Shore. If such an option is chosen, it is important to consider however, the scale of work involved, which would be concomitant with that for the structure to replace the existing Champlain Bridge. It would also have to solve the problem of the Île des Sœurs crossing and the construction of a station at that location, given recent and future developments and the changes that will be made to road infrastructures between the new Champlain Bridge and the new Île des Sœurs Bridge. The age of the Ice Control Structure would also need to be considered; studies previously conducted date from 1999 and 2004 and do not necessarily reflect the current state of the structure nor what it will be at the time the work would be done.

6.2 The existing Champlain Bridge

6.2.1 Maintenance

With respect to the structure of the existing Champlain Bridge, the Consortium analyzed its maintenance costs in order to make an extrapolation based on the results and earlier budget projections by JCCBI. Annual expenditures rising from \$18 to \$25 million over the next ten years, increasing at a constant rate, would be necessary to prolong its life, without in any way improving the level of seismic performance or rehabilitating the bridge deck. The maintenance work will become increasingly extensive and complex and require increasingly long lane closures and ever greater inconvenience for users.

6.2.2 Seismic resistance

The concrete superstructure of the existing Champlain Bridge, which represents nearly 80% of its total length, has the characteristic that the top flanges of the girders are part of the deck. This means that deterioration of the deck results in a deterioration of the girder flanges. Rehabilitation of the deck, virtually unavoidable after so many years of service, would imply the complete reconstruction of all the spans.

A seismic analysis has demonstrated substantial lack of resistance in the piers, even without considering their degree of deterioration. Analysis of an option using the piers to carry a new

structure for a LRT, with a lighter and narrower steel deck, also revealed a substantial lack of seismic resistance.

6.2.3 Demolition

Demolition of a civil engineering structure like the existing Champlain Bridge is a singular challenge, not just for Montréal but even for Québec and elsewhere in Canada. The demolition scenario and the related costs shown in the report are based on research done on the Internet and calculations to translate the demolition activities into time periods and costs. Demolition would consist essentially of successively dismantling the spans while taking into account seaway use, environmental restrictions and the winter season.

The demolition method is based on the principle of sawing the spans and concrete piers using diamond wires and removal of whole steel spans, followed by their being taken apart into single components. The concrete spans would be demolished using launch trusses supported on the piers; the sawed blocks would be transported by barges to a site on the jetty along the seaway. A two-front approach is proposed for demolition of the concrete structures. For the steel sections, dismantling would start from the deck, and whole spans would be taken down on barges to continue the dismantling away from the Seaway. It has been estimated that the demolition work would extend over a period of nearly three years. The total demolition cost is estimated at about \$155 million. The possibility of demolition by explosion was studied; however, it is the opinion of the Consortium that this method is not applicable, mainly because of environmental restrictions.

The demolition method was reviewed and discussed with experts from the firm of EXCOTECH, which has extensive experience in the field.

7 ENVIRONMENTAL ASPECTS

7.1 Process and methodology

Identification of environmental aspects is based entirely on a review of the literature available from JCCBI, the MTQ, government organizations and public documentation centres, as well as some telephone interviews conducted in 2010. A request for information was also made to the Centre de données du patrimoine naturel du Québec (CDPNQ), for which documents were obtained in March 2010. No data have been collected in the field.

7.2 Main human and natural constraints of the site

The first constraint is the presence of two Amerindian archaeological sites on the northern point of Île des Sœurs near the tunnel and bridge options alignment. Although they are classified sites in the meaning of the *Cultural Property Act*, they enjoy protection status from the Ministère des Affaires culturelles, des Communications et de la Condition féminine (MACCCF) and the Ville de Montréal. Moreover, this site has had spiritual importance for the Mohawk community of Khanawake since the remains of a child buried there were exhumed during recent archaeological digs. Any construction over this site will probably have to be the subject of an agreement with the MACCCF, the Ville de Montréal and the Mohawk community.

The second major environmental constraint is the required protection of plant communities that serve as spawning grounds for several fish species. These sensitive environments are located on the alignment of the tunnel and bridge options at Île des Sœurs and the Seaway (channel and basin). Any destruction of a portion of these habitats will require implementation of environmental compensation measures. Moreover, in-water work is subject to restriction periods associated with use of the river and Seaway waters by fish species during sensitive stages of their reproductive cycle: restriction from December 20 to July 31.

The third major environmental constraint is the proximity of the existing Champlain Bridge to the migratory bird sanctuary on Île de la Cuvée. The alignment of the tunnel and bridge options crosses this sanctuary and will require federal and provincial environmental authorizations, since it is prohibited to disturb sensitive species that visit the sanctuary from April 1 to October 31.

The last major constraint is the existence of large residential sectors on Île des Sœurs, the Island of Montreal (Sud-ouest borough) and the South Shore. The two latter sectors are especially sensitive to the bored tunnel options that require substantial work (risk of nuisances) and expropriations. The current and developing residential sectors on Île des Sœurs are more sensitive to the under-river tunnel and bridge options because the new structures will be built there and substantial traffic can be expected at the site.

In addition to the major constraints is a secondary constraint that must receive attention in the later stages of the project. Information obtained from Environment Canada’s St. Lawrence Centre indicates that there is contamination of sediments exceeding harmful environmental thresholds in the Seaway at the Champlain Bridge (channel and basin). Work planning will have to include updating the data and environmental management of any confirmed contamination.

7.3 Anticipated impacts of the bridge options

The bridge options were tested for identified environmental constraints and the analysis revealed that the solutions are comparable. In fact, the alignments and abutments considered are identical, and the number of piers similar. Only the location of the piers differs in the various solutions. Accordingly, for analysis purposes, the bridge solutions were classified in two families, one with aligned piers and one with offset piers. Table 7-1 presents the summary of this analysis. This analysis reveals that the bridge solutions have little impact, except for the archaeological sites. The environmental compensation costs for the loss of fish habitats would be relatively small (estimates below \$1 million). The offset pier solutions would be slightly more favourable than the aligned pier solutions, especially for sensitive natural environments.

7.4 Anticipated impacts of the tunnel options

The tunnel options were also tested for identified environmental constraints. Table 7-2 shows a summary of this analysis. In the shallow under-river solutions, option 1 refers to the dry-bed cofferdam construction method, while option 2 refers to the construction using immersed caissons. In an absolutely way, drilled tunnel solutions limit virtually any impact on sensitive natural environments and on archaeological sites. On the other hand, these solutions present the greatest impacts on sensitive human environments because of the required expropriations and nuisances that could appear. For the shallow under-river solutions, the analysis reveals that using the dry-bed cofferdam construction method presents less environmental impact, especially in sensitive natural environments. Despite this advantage, temporary and permanent destructions of fish habitats are expected, and the environmental compensation costs are estimated to be \$30 million. As for the bridge options, the presence of archaeological sites will create a major challenge for an under-river tunnel.

Table 7-1: Comparative environmental multicriteria table for various bridge solutions

CRITERIA	ALIGNED PIER BRIDGE	OFFSET PIER BRIDGE
Contamination zones	Excavation in potentially contaminated sediments if shallow foundations.	Excavation in potentially contaminated sediments if shallow foundations.
	Environmental characterization required before the work.	
Sensitive natural habitats	Permanent destruction of spawning zones and plant communities at the level of 10 piers (about 200 m); temporary destruction of spawning zones and water plant communities in	Permanent destruction of spawning zones and water plant communities near 6 piers (about 120 m); temporary destruction of spawning zones and water plant communities in the

CRITERIA	ALIGNED PIER BRIDGE	OFFSET PIER BRIDGE
	the cofferdams for the construction of their shallow foundation (about 2,100 m); permanent destruction of fish habitat near 60 piers and temporary destruction of fish habitat in the cofferdams for the construction of their shallow foundation.	cofferdams for the construction of their shallow foundation (about 1,400 m); permanent destruction of fish habit with 62 piers and temporary destruction of fish habitat in the cofferdams for the construction of their shallow foundation.
Sensitive human habitats	Visual impact and sound nuisances during the construction phase close to in residential zones.	Visual impact and sound nuisances during the construction phase close to residential zones.
Archaeological sites	The alignment chosen provides for the construction of abutments directly above two archaeological sites requiring protection.	The alignment chosen provides for the construction of abutments directly above two archaeological sites requiring protection.
Demolition	N.A.	N.A.
Management of excavation products	N.A.	N.A.
Period for restricting in-water work (Dec. 20 to July 31).	Installation of cofferdams allows work on dry land and thus work outside the restriction period.	Installation of cofferdams allows work on dry land and thus work outside the restriction period.
Period of restriction on disturbing the migratory bird sanctuary (April 1 to October 31)	Work near the sanctuary must be planned outside the restriction period or by using mitigation measures.	Work near the sanctuary must be planned outside the restriction period or by using mitigation measures.
Mitigation measures	Mitigation measures: temporary and permanent loss of fish habitat, Cost = about \$832,000	Mitigation measures: temporary and permanent loss of fish habitat, Cost = about \$743,000\$

In Figures 7-1 to 7-3, the rating of each of the solutions is represented by a “colour code” defined as follows:

green = favourable **yellow** = barely favourable **red** = unfavourable **black** = very unfavourable

Table 7-2: Comparative multicriteria environmental table between various tunnel solutions

CRITERIA	DRILLED TUNNEL	UNDER-RIVER TUNNEL
Contamination zones	No excavation in sediments that could be contaminated. But the alignment crosses a sector with high contamination potential on the left shore.	Options 1 and 2: No excavation in highly contaminated zone on the left shore. But major excavations in potentially contaminated sediments.
	Environmental characterization required before the work.	
Sensitive natural	No sensitive habitat disturbed and no	Option 1: Destruction of a spawning

CRITERIA	DRILLED TUNNEL	UNDER-RIVER TUNNEL
habitats	seasonal operation restriction.	area and water plant community in the prefabrication cofferdam on the right shore (± 5 ha); destruction of fish habitat in the cofferdams in the river and partial destruction of a spawning zone and a habitat for a vulnerable species on Île des Sœurs (± 1 ha). But possibility of isolating the work site from the river by cofferdam, limiting pollutant dispersion. Option 2: Destruction of a spawning zone or a water plant community in the prefabrication cofferdam on the right shore (± 5 ha); total destruction of a spawning zone and a habitat of vulnerable species on Île des Sœurs (± 15 ha); destruction of fish habitat in the excavation and risk of dispersion of pollutants by using marine measures to create the excavation.
Sensitive human habitats	Reduction of visual impacts and nuisances on Île des Sœurs. But major expropriations required during the construction phase, substantial nuisances during construction, no architectural signature and loss of a panoramic view of Montréal and the river from the bridge.	Options 1 and 2: Reduction of visual impacts. But no architectural signature and loss of a panoramic view of Montréal and the river from the bridge and major nuisances during construction on Île des Sœurs.
Archaeological sites	No impact.	Options 1 and 2: The chosen alignment has excavation directly at the two archaeological sites requiring protection.
Demolition	N.A.	N.A.
Management of excavation products	Major quantities of residue to manage with significant transit of material and heavy equipment in residential zones.	Options 1 and 2: Major quantities of residue to manage. Even if possibility of reuse of certain materials to ballast the tunnel and restore the river bed.
Period of in-water work restriction (December 20 to July 31).	No impact	Option 1: Installation of cofferdams allows "dry land" work and thus working during the restriction period. Option 2: Use of marine equipment for creating the excavation will be impossible during the restriction period.
Restriction period on disturbances in the migratory bird sanctuary (April 1 to Oct. 31)	No impact	Options 1 and 2: Work near the sanctuary must be planned outside the restriction period or with use of mitigation measures.
Environmental compensation measures	None	Major compensation measures required: temporary fish habitat loss over an area of about 60 ha. Cost = about \$30 million

7.5 Anticipated impacts of the demolition options

Two demolition options were considered and studied: controlled explosion and deconstruction. Analysis of the anticipated impacts reveals that the controlled explosion option is much less attractive because of the major impacts it would have on the sensitive habitats of the water plant communities and spawning grounds. Deconstruction is more attractive because it offers few environment risks except for the mitigation measures that will have to be implemented during the work to limit disturbance of the migratory bird sanctuary. Table 7-3 below presents a summary of this analysis.

Table 7-3: Comparative environmental multicriteria table of the various demolition options

CRITERIA	CONTROLLED EXPLOSION	DECONSTRUCTION
Contamination zones	Major quantities of contaminated sediments disturbed.	No impact.
Sensitive natural habitats	Destruction of spawning zones and water plant communities found beneath the existing bridge.	Possibility of temporary destruction of spawning zone and water plant communities beneath the transport barges.
Sensitive human habitats	Limited impact on navigation.	No impact.
Archaeological sites	No impact.	No impact.
Excavated materials/waste management	Diffuse pollution created and more difficult recovery of materials and debris. Major quantities of residue to management with substantial transport of heavy material through residential zones. But river transport and recycling materials possible.	Major quantities of residue to management with substantial transport of heavy material through residential zones. But river transport and recycling materials possible.
In-water work restriction period (Dec. 20 to Jul. 31)	Impossible during the restriction period.	Use of barges is not considered in-water work. Limit the installation/moving of fixed barges during the restriction period from December 20 to July 31.
Restriction period for disturbance in the migratory bird sanctuary (April 1 to Oct. 31)	Impossible during the restriction period.	Work near the sanctuary must be planned outside the restriction period or by making use of mitigation measures.
Mitigation measures	Need to introduce major mitigation measures to control diffuse pollution.	Mitigation measures required to limit disturbance at the migratory bird sanctuary.

7.6 Legal, regulatory and administrative requirements

One last constraint to be integrated in the actual project planning is the obligation to conduct an environmental impact study to satisfy federal and provincial requirements in this area and obtain appropriate authorizations from Fisheries and Oceans Canada, Transport Canada, the Ministère du Développement durable, de l'Environnement et des Parcs du Québec (MDDEP) and Ressources naturelles et de la Faune du Québec (MRNF). If most of the environmental authorizations are generally obtained some time before the work, when the final plans and specifications and work methods are known, the environmental impact study must be conducted early in the planning process because it involves holding public hearings. It is generally accepted that such a process takes 24 months to complete and JCCBI should set aside a budget in the order of \$2 million to execute the formal environment impact study and the holding of public hearings.

8 CAPITAL AND OPERATING COSTS

Table 8-1 summarizes the preliminary capital costs required to execute the project, using the cable-stayed bridge solution and tunnel built with cofferdams solution as examples. While the tunnel solution selected is the obvious one, based on the recommendation in Chapter 6, the bridge solution used in the estimate was selected only as an example, since the 5 solutions analyzed in Chapter 5 have construction costs that differ only within a range of about 10%.

Table 8-1: Capital cost of bridge and tunnel solutions

ITEMS	BRIDGE OPTION ¹ \$million ₂₀₁₀	TUNNEL OPTION ² \$million ₂₀₁₀
Preliminary design	10.5	13.2
Complementary studies ³	4.7	8.8
Environmental studies	2.0	2.0
Land acquisitions	3.0	4.0
Detailed Engineering (Plans and specs)	30.0	19.8
Supervision of construction	69.0	33.0
Control of materials	19.0	11.6
Project management	14.0	21.2
Civil engineering works, bridge or tunnel	910.0	1,382.9
Civil engineering works, approaches	34.0	44.4
Operation systems and equipment	9.5	142.3
Traffic management during construction	10.9	28.7
Relocation of public utilities	10.0	10.0
Environmental compensation measures	0.9	30.0
Demolition of existing bridge (Prof. fees and works)	155.0	155.0
TOTAL	1,282	1,907

1: Cable-stayed bridge

2: Under-river bridge, built within cofferdams

3: Includes studies on traffic, THG, topography, geotechnical, hydraulic and ice flow, and archaeological digs

Those level D estimated costs, including a margin of error of 20 to 30%, do not include the following elements:

- ▶ Special facilities and fixed installations associated with an LRT (light rail transport) or a BRT (bus rapid transit service);

- ▶ Implementation of the ELPT infrastructure (LRT or BRT) between the west extremity of the existing Champlain bridge replacement structure and its connexion to the existing network on Montréal Island;
- ▶ Implementation of a bicycle path;
- ▶ Renovation or demolition of the ice control structure;
- ▶ Modifications or replacement of the Île des Sœurs bridge;
- ▶ The buildings required for the ITS control centre or for maintenance;
- ▶ Renovation and widening of A-15 between the Île des Sœurs bridge and the Atwater interchange;

Tables 8-2 and 8-3 present a very preliminary estimate of the annual maintenance and operating costs of a bridge and a tunnel respectively, expressed in 2010 dollars. It can be seen that a tunnel solution generates annual costs twice as large as a bridge solution.

Table 8-2: Representative Annual Operating and Maintenance Costs of a Bridge Solution

ITEMS	INTERVENTION INTERVALS , Years	ANNUAL AVERAGE COSTS, Thousand \$ ₂₀₁₀
Operation and regular maintenance	1	3,780
ITS installations	15	333
Lighting and overhead signs	25	220
Replacement of premix asphalt	8	1,803
Replacement of the membrane	16	952
Replacement of the expansion joints	25	262
Replacement of supporting devices	25	539
Average total annual cost based on 35 years, in 000s of 2010 dollars		7,889

Table 8-3: Representative Annual Operating and Maintenance Costs of a Tunnel Solution

ITEMS	INTERVENTION INTERVALS , Years	ANNUAL AVERAGE COSTS, Thousand \$ ₂₀₁₀
Operation	1	4,020
Regular maintenance	1	3,900
Replacement of premix asphalt on approaches	8	229
Replacement of premix asphalt in tunnel	25	173
Electrical power supply	25	1,577
Ventilation	25	626
Lighting	20	165
Signaling systems and equipment	12	223
Fire protection equipment	20	16
Fire detection equipment in en tunnel	12	55
Control Center	12	275
Vidéo monitoring in tunnel and at exits	12	492
Emergency phone system	12	138
Telecommunication	12	346
Telephone system	12	19
Maintenance Center	20	373
Outdoor equipment at tunnel ends	15	190
Équipement in ELPT tube	20	890
Computer equipment and softwares at Control Center	12	1,113
Recurrent annual expenses	1	470
Average total annual cost based on 35 years, in 000s of 2010 dollars		15,289

9 FINANCIAL CONSIDERATIONS AND METHODS OF DELIVERY

This chapter mainly examines the financial aspects and the viability of the project and possible methods of project delivery. It looks first at the compensation to be paid for the use of the Champlain Bridge for public transport in reserved lanes areas or the passage of public utilities.

It then examines the various possible delivery methods, with their advantages and disadvantages, as well as the cash flows inherent in each of these modes. It suggests possible approaches to distributing the costs among the various levels of government.

Finally, there is an evaluation of the economic spin-offs generated by the project, using the Institut de la statistique du Québec intersector model.

9.1 USE OF THE BRIDGE FOR THE PASSAGE OF PUBLIC UTILITIES

The basic principles of the agreements to be signed with public utility services must be oriented on the following basic principles:

- ▶ Public utility service organizations must of course pay the capital and operating costs they generate in order to be able to use the infrastructure, representing a source of revenue for the owner of the structure over a long period;
- ▶ These public utilities must never cause disruption of traffic on the new structure due to equipment breakdown or maintenance work;
- ▶ In case of breakdown, they must not be a source of danger for the users or the bridge structure.

At this time, JCCBI receives very little revenue from rent from public utilities.

9.2 PROJECT DELIVERY METHODS

In developing a project, it is vital to define the needs and constraints as accurately as possible (this is the concept of “defining the project at the outset”), whatever delivery method is chosen for building the structure. Any modification that affects the needs analysis will undoubtedly result in delivery delays and cost overruns. It is therefore important to prepare a complete and final detailed study that defines the project clearly and establish a procedure that will manage any changes and minimize their financial impact.

There are many delivery methods for public projects, and they can be classified according to the degree of risk-sharing between the public body and the private sector.

For the purposes of this report, three modes were analyzed:

- ▶ traditional,

- ▶ design-construction,
- ▶ public-private partnership.

The comparison criteria selected were:

- ▶ flexibility with respect to changes while the project is underway,
- ▶ respect for the execution schedule,
- ▶ risks of cost overruns,
- ▶ optimization of the design throughout the project lifecycle,
- ▶ project financing costs.

The traditional mode is the one that best accommodates project changes during execution. Generally, such changes result in delays and cost variations but these are less significant than in the other two forms of execution because the risks associated with the cost and execution schedule remain the responsibility of the client.

In design-construction or PPP, the bid by the entrepreneur contains a fixed price for a precise deliverable determined through a competitive process. Any change requested to this deliverable after the contract is signed must be negotiated with consideration for its impacts on the project schedule and conduct.

Scheduling risks are greater if the traditional execution method is used. Since various activities occur in sequence, with each of them having to be completed before the next one starts and funded by an annual budget. The form of governance of the public body may also influence the execution schedule. In this delivery method, any delay in one activity can continue to have an impact until the final acceptance of the structure and affect the budget equilibrium of the sponsoring organization.

In design-construction and PPP modes, payments are generally only made when all of the work has been completed and accepted by the client. This form of payment on delivery incites the designer-builder or private partner to complete the project as soon as possible in order to get paid and reduce their short-term financing expenses.

Risks of cost overruns to the client are much more limited if PPP or design-construction modes are selected. In both, the cost of the structure is established when the contract is signed and any cost overrun is generally assumed by the partner.

In the traditional mode, it is generally the client who pays for cost overruns. The client must find the financing necessary to pay them or reduce the project scale.

Optimization of the design on the whole project life cycle is a criterion that favours execution of the project in PPP mode compared to the other two modes.

In PPP mode, the partner will be responsible for maintenance, operation and rehabilitation for a long period, for 25, 30 or even 35 years. Accordingly, it will try to make choices during project execution that will maximize its profits throughout the partnership contract. It will favour synergy between the designers and the entrepreneurs to promote innovations that reduce the total costs of the project for its useful life. Given the long operating period under the responsibility of the private partner, the client may allow it to deviate from traditional methods and introduce technological innovations at its own risk.

In design-construction mode, the client must pay special attention to ensure that the performance criteria are respected during the construction period, and it may choose to impose certain technical criteria on elements, especially those that will have an impact on the maintenance and operation of the facility throughout its life cycle and on the useful life of the facility.

In traditional mode, it can happen that in order to respect its budget and schedules, the client makes choices that will impact unfavourably on maintenance and operating costs throughout the life cycle of the structure.

The financing cost of the project criterion favours traditional delivery method. The governments, both provincial and federal, can borrow on the markets, both bond and short-term, at lower interest rates than the private sector can.

In conclusion, it is difficult to determine the ideal delivery method for a project of the scope of the reconstruction of the Champlain Bridge. Deeper analyses of the added value will allow the advantages and disadvantages of each of the modes to become clearer and a choice as a function of the client's needs and constraints.

In Canada, an added-value analysis method has been developed in three provinces (Québec, Ontario and British Columbia) and is used to determine the wisdom of executing the project in traditional, design-construction or public-private partnership mode. These methods allow a rigorous analysis of each of the projects.

BCDE recommends that JCCBI undertake this type of value analysis, even if it is not required to do so.

These different project delivery methods are distinguished mainly by the share of the risks the public entity is ready to accept in order to have an installation built or a service offered to the public. These risks are analyzed and distributed among the main players according to their capacity to manage them.

Risk-taking by the private enterprise has a price that will inevitably be transferred to the public enterprise and added to the project execution cost. Project success is based largely on properly

identifying these risks and determining whether it is worth the effort of transferring them to the partner or they should be assumed by the public entity.

9.3 PROJECT SCHEDULES ACCORDING TO DELIVERY METHODS

The schedules shown in Figure 9-1 contain only the major project steps, as a function of the three delivery methods analyzed.

The lengths of the activities are based on recent examples of major projects and internal discussions. They are not final, however, and the durations ultimately adopted may deviate significantly from those shown here.

Although it is not usual to prepare a business case for the conventional mode, it was decided to include one in the schedule to be fully consistent with the relevant recommendation and because of the size of this project.

The schedule shown here is intended only to compare the execution times for the 3 modes analyzed. To determine the full duration of the project, the preliminary detailed design and the decision-making process to authorize initiation of the project must be added.

9.4 CASH FLOW ANALYSIS

9.4.1 Cash flows according to delivery methods

Based on the estimates of construction, maintenance and operation costs and the critical path, financial flows were produced for each of the bridge and tunnel options, and in each case, for each of the three delivery methods: conventional, design-build and public-private partnership.

For each of the three delivery methods, financial assumptions were proposed, some applying to some modes and not to others. A sensitivity analysis was also conducted to measure the impact of the results obtained after modifying certain of these assumptions.

Only the capital, operation and maintenance expenditures were taken into account in the financial flow analysis. Any potential revenues from tolls or other revenue sources that might be generated by the new structure were not considered.

The current financial situation makes it difficult to make long-term forecasts of interest rates (both short and long term loans) both for governments and the private sector. The same applies to the long-term inflation rate and the discount rate.

The period selected for establishing the average of both long and short-term interest rates covers a relatively intense period of economic activity, followed by a recession and then a period of weak recovery. The period from July 2007 to July 2010 (April 2010 for long-term borrowings by the Government of Canada) was used because it contains a period of interest rates during strong economic activity, in 2007 and a portion of 2008, a period of recession in 2008 and 2009, and recovery with weak economic activity in 2009 and 2010.

For each of the three delivery methods, all expenditures are financed by short-term loans until commissioning of the new structure. The average short-term rate of the Canadian government is used for conventional mode and the short-term rate of private businesses is used for the design-build and public-private partnership modes.

The total expenditure amount is borrowed, either at the long-term Canadian government rate, for conventional or design-build modes, or at the long-term rate for Canadian corporations for public-private partnership mode. The amortization period for these loans remains the same, whatever the mode, at 35 years after the structure is commissioned.

The residual value of the structure was estimated for each of the delivery methods and for the bridge or tunnel options. Linear depreciation, as proposed by the MTQ in its guide to cost-benefit analysis of public transportation projects, was used and the useful life of the structure was estimated at 75 years for the financial analysis.

Capital, operating and maintenance expenditures were first estimated in 2010 dollars. These amounts will in fact be invested throughout the useful life of the project. It is thus important to correct them with an inflation factor in order to better reflect the reality of the time when they are actually spent..

There is no price index specifically designed for civil engineering projects in general and even less for the construction of a bridge or a tunnel. Accordingly, the target inflation rate of the Bank of Canada of 2% has been used. This rate is the one that allows inflation in Canada to be controlled.

The execution costs of projects may vary as a function of how they are executed. As mentioned in the previous sections, the design-build and public-private partnership modes can allow savings of time during construction that can turn into cost savings.

The transfer of risk from the public entity to the design-builder or the private partner has a monetary value that will be included in the proposals received by the public entity if it retains these delivery methods.

For this financial analysis, an identical capital cost for all delivery methods was used first. A sensitivity analysis will make it possible to measure the impact of a variation in this cost by execution mode.

Discounting is a method used to express financial flows that cannot be directly compared on the same base because they occur at different times. This not only allows them to be compared but also to be subject to arithmetic operations.

Discounting is based on three fundamental principles:

- ▶ Inflation
- ▶ Preference for immediate payment
- ▶ Risk aversion.

The discount rate used in this study is the one now used by the MTQ in the analysis of its projects. It roughly represents the current rate of return of the Québec economy, currently estimated at 3.3%. A sensitivity analysis will be performed to measure the variation of the results given a fluctuation in the discount rate.

All expenditures for the execution of the new structure are financed through short term loans until commissioning. The total amount is then refinanced by a long-term loan over a period of 35 years. The borrowing terms are specific to each of the delivery methods and are defined above.

Demolition of the current bridge begins as soon as the new structure is opened and takes three years to complete. The funds for these works are borrowed at short term rates until they are completed. They are then refinanced at long term rates and amortized over a 10-year period.

Maintenance expenses, both current and periodic, are recognized in the year in which they occur and are indexed, as are operating expenditures.

A residual value is attributed to the structure in the thirty-fifth year according to linear depreciation method.

The current value of financial flows for the bridge option indicates that execution in conventional mode is the one that generates the least expenditure in current dollars with a negative value of (\$1,559.84 million). The design-build mode has a current value of (\$1,799.41 million) and public-private partnership mode (\$2,043.63 million).

The present value of financial flows for the tunnel option indicates that execution in conventional mode generates the least expenditure in current dollars with a negative value of (\$2,494.5 million). The design-build mode has a current value of (\$2,583.30 million) and the public-private partnership mode (\$3,103.02 million).

It should be noted that, in both cases, these values exclude values associated with risks. A more intensive analysis, to be done in the business plan, will make it possible to evaluate them and include them in the financial analysis. The ranking of delivery methods could then change.

9.4.2 Sensitivity analysis

A sensitivity analysis was conducted for the bridge option. It involved the following indicators:

- ▶ Capital costs
- ▶ Long-term interest rates
- ▶ Short-term interest rates
- ▶ Inflation rate
- ▶ Discount rate

The analysis consists of raising or lowering each of the indicators mentioned above while keeping the others unchanged for each execution mode and verifying whether their ranking changes

9.4.2.1 Construction Costs

Sensitivity analysis of the financial flows shows that a fairly small variation (approximately 3% for the bridge and 5% for the tunnel) of the construction costs for the design-build mode will change the results, ranking-wise.

For the PPP mode, a reduction of the construction costs of just under 20% for the bridge and 26% for the tunnel would bring its financial flows under those of the traditional mode

Ranking of the delivery methods is quite sensitive to construction costs

9.4.2.2 Short Term Interest Rates

The variation of short-term interest rates can influence the results for the bridge option. If the design-builder manages to obtain short-term financing at less than 2.5% and the government maintains its rate at 1.9%, this mode (design-build) would become the most attractive compared to the two others.

The tunnel option is not sensitive to short terms interest rates. If the Government rate was held at 1.9%, the design-builder would have to get a short term rate of less than 2.5% for the design-build method to become more attractive than the other two.

9.4.2.3 Conclusion

Financial flows analysis indicates, at this stage of the project, that the traditional mode of execution would be a better choice, both for the bridge and the tunnel option.

The sensitivity analysis shows that the results are sensitive to capital costs and short term interest rates. Variations of the other factors will not influence the ranking of the execution mode.

Risk related cost variations were not considered at this stage. They should be covered by the added value analysis (or the business plan) and included in the financial analysis at that moment. Those risks related costs could have an impact on the ranking of the delivery methods.

9.5 ECONOMIC IMPACTS OF THE PROJECT

A study was conducted on the economic impact for Québec of the capital expenditures associated with the construction of a bridge and a tunnel in Québec, using the intersectoral model of the Institut de la statistique du Québec.

This model is an instrument that makes it possible to simulate and then express, in economic terms, the effects of certain real, expected or hypothetical changes in our economy. These changes consist of various projects involving capital, operating or current consumption expenditures.

The projects simulated using this model imply outlays that have an impact on the economy in terms of production, revenues, jobs, imports, etc. The model makes it possible to measure these effects and classify them according to whether they appear in the sectors immediately affected by the initial expenditures (direct effects) or take place in industries that supply the ones in which the first effects are felt (indirect effects).

First, a simulation for the bridge option with capital expenditures of \$1.3 billion was conducted. Next, the same type of simulation was done for the tunnel option with capital expenditures of \$1.9 billion. The following results come from the report produced by the ISQ. A complete version of the report is appended to this document.

The total effects of capital expenditures of \$1.3 billion associated with the construction of a bridge in Québec would be:

- ▶ on labour, 9,662 person-years at a payroll of \$503.7 million;
- ▶ on individual companies, 918 person-years of self-employed workers for net revenue of \$39.1 million;
- ▶ on value added to the basic price of \$868.0 million.

The capital expenditures of \$1.3 billion for the bridge option would generate:

- ▶ total revenues for the government of Québec of \$61.7 million, of which \$41.5 million in income taxes on salaries and fees, \$5.7 million in sales taxes (QST) and \$14.5 million in other taxes;
- ▶ total revenues for the federal government of \$39.7 million, including \$32.5 million in income taxes on salaries and fees, \$396,000 in sales tax (GST) and \$7 million in excise and other taxes;
- ▶ revenues from incidental Quebec and federal taxation of \$100.1 million and \$13.2 million, respectively.

The total effects of capital expenditures of \$1.9 billion associated with the construction of a tunnel in Québec would be:

- ▶ on labour, 14,353 person-years with a payroll of \$744.9 million;
- ▶ on individual companies, 1,229 person-years of self-employed workers for a net revenue of \$57.0 million;
- ▶ on the value added to the basic price of \$1,295.0 million.

The capital expenditures of \$1.9 billion for the tunnel option would generate:

- ▶ total revenues for the government of Québec of \$91.4 million, of which \$61.0 million in income taxes on salaries and fees, \$8.5 million in sales taxes (QST) and \$21.9 million in specific taxes;
- ▶ total revenues for the federal government of \$58.9 million, of which \$47.9 million in income taxes on salaries and fees, \$580,000 in sales taxes (GST) and \$10.4 million in excise and other taxes;
- ▶ revenues from incidental Québec and federal taxation of \$149.8 million and \$19.5 million, respectively.

Annexe 1 Elevations and cross sections of 5 “bridge” solutions (5 pages)

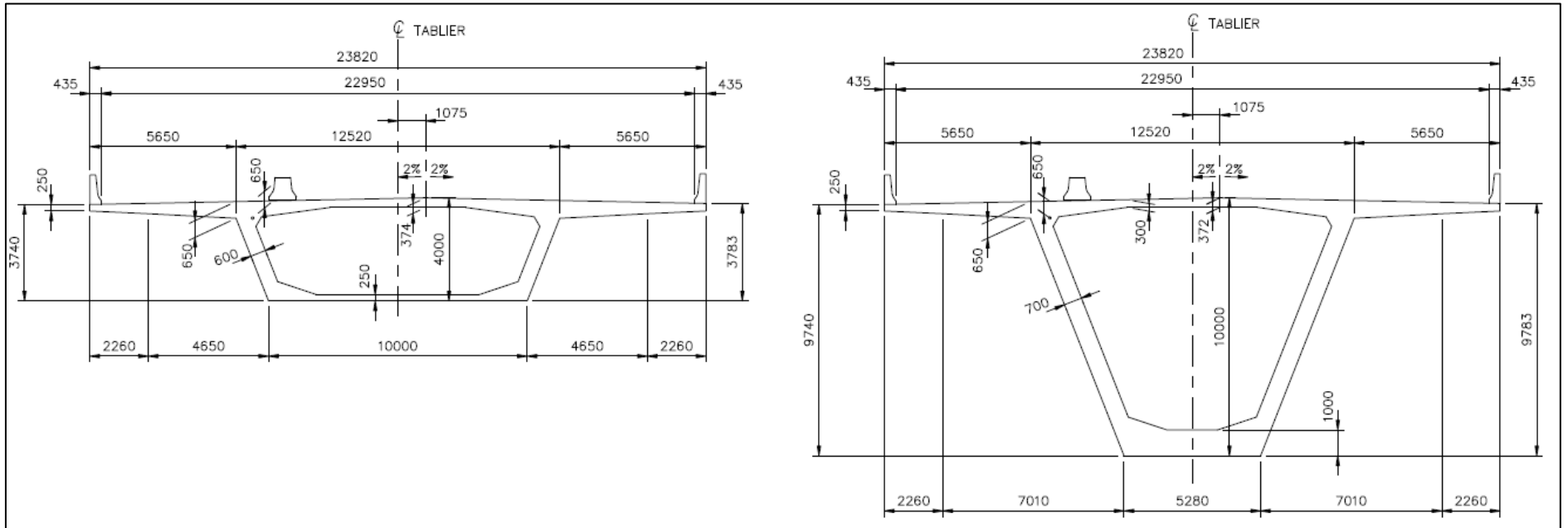
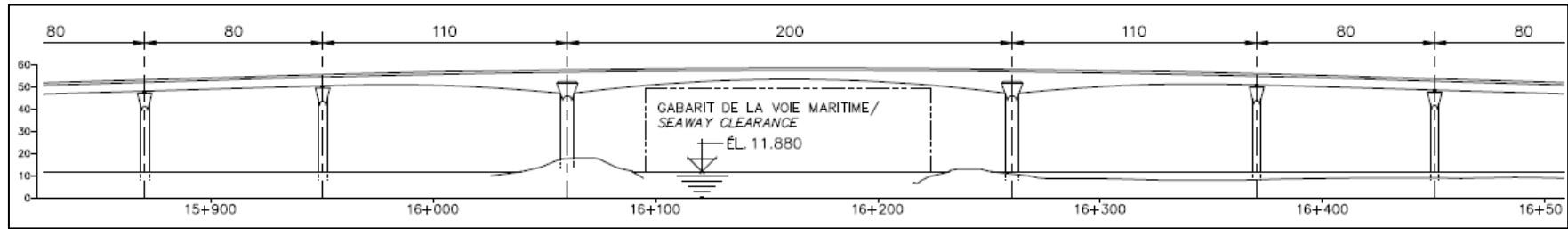

Prestressed concrete monocaisson

- Principal span of 200 m (Seaway)
- Built by successive cantilevers
- Standard spans of 80 m

CT 61100

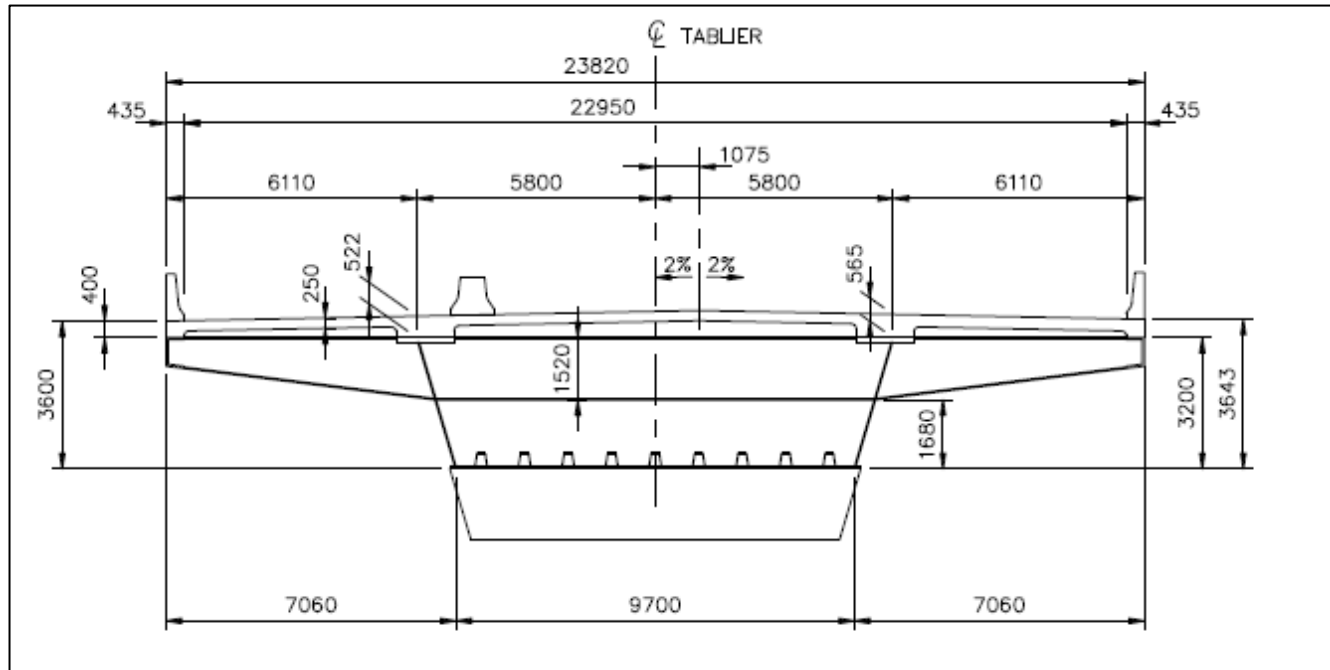
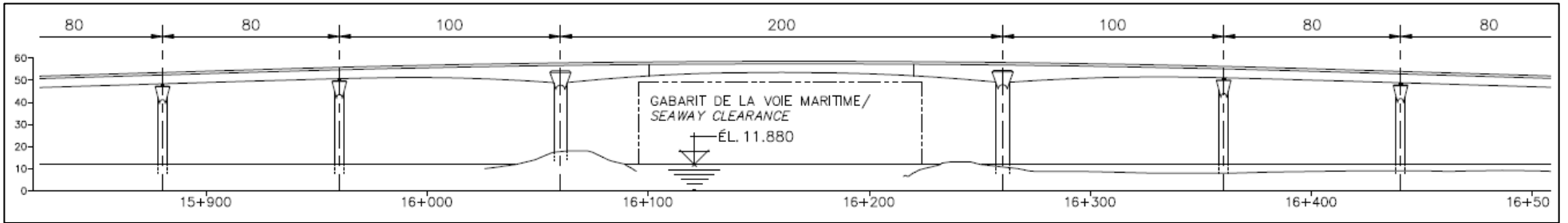

Steel-concrete composite bridge

- Principal span of 200 m
- Built by hoisting (central section) and overhang (concrete section)
- Standard spans of 80 m of mixed framework

CT 61100

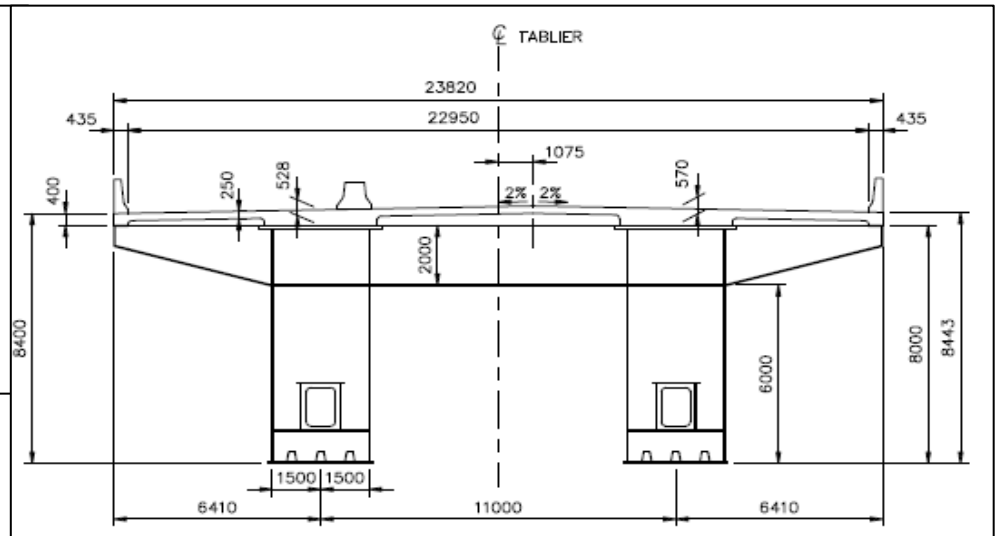
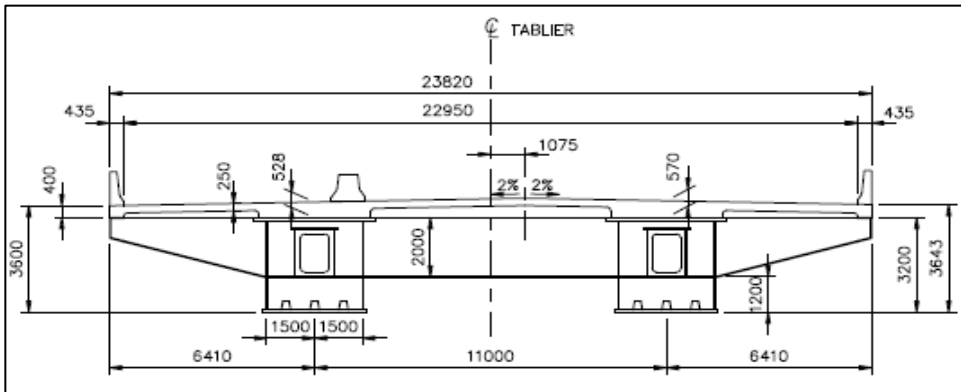
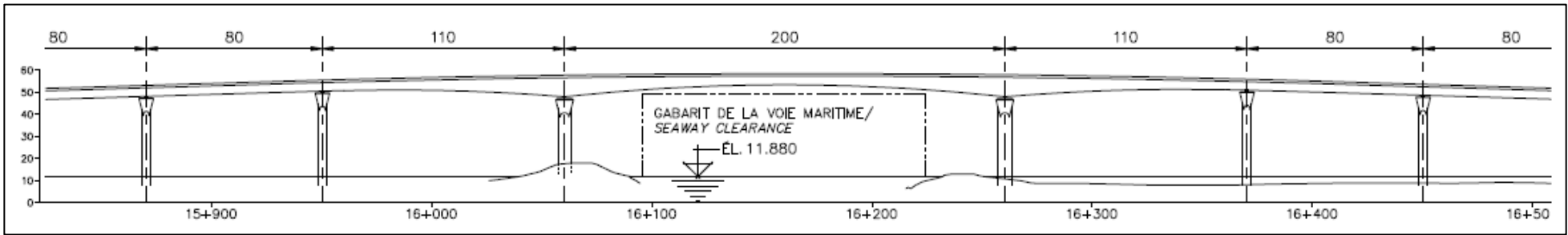

Mixed framework bridge

- Main span of 200 m launched from both sides
- Several cross-sections possible (double girder, double box caisson and single box caisson)
- Standard spans of 80 m in mixed framework

CT 61100

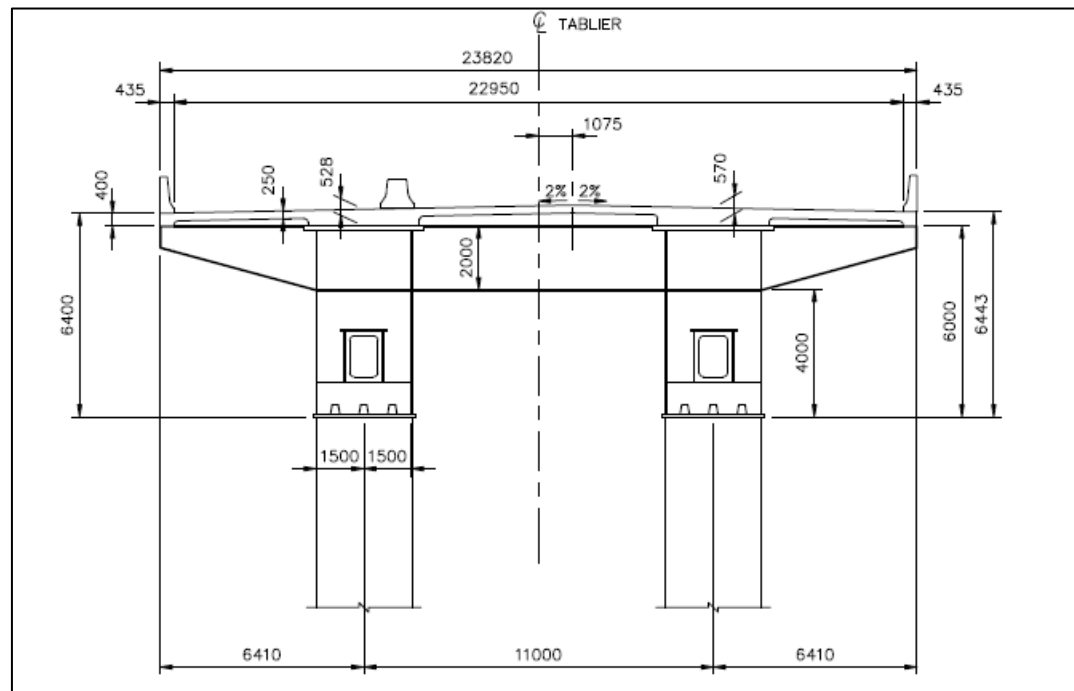
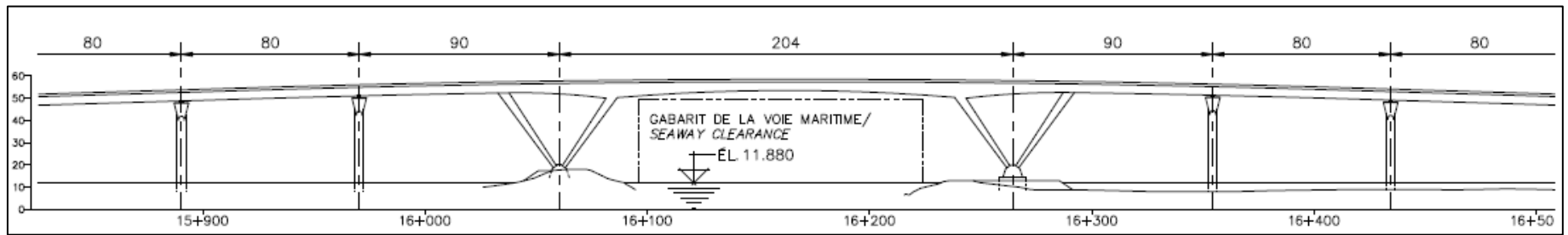

Mixed framework bridge with V-shaped piers

- Span of 204 m of which 155 m between the Vs, launched from one side. Standard spans of 80m in mixed framework
- Several cross-sections possible (dual girders, dual box caissons and single box caisson)

CT 61100

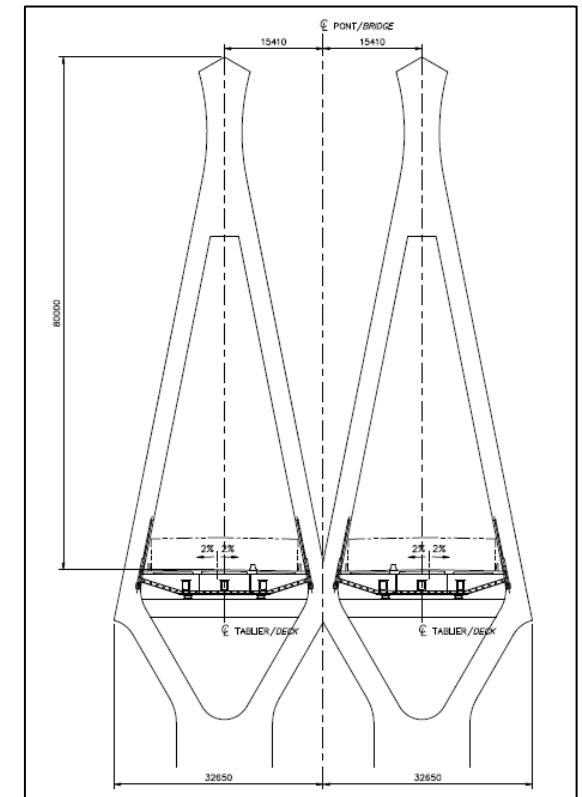
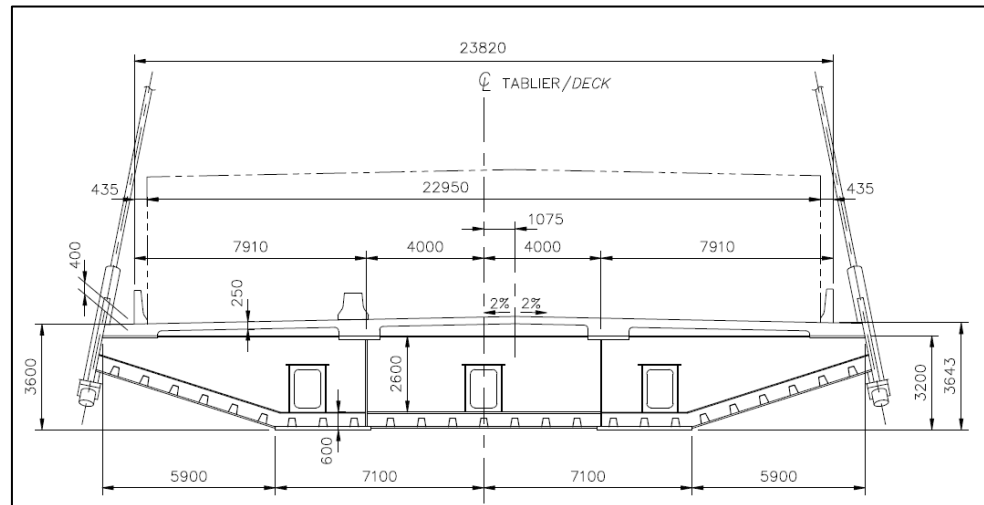

Cable-stayed mixed framework bridge

- Principal span of 200 m
- A single pylon per deck, with two masts transversally
- Standard spans of 80m with mixed framework

CT 61100

